

CALICE: A calorimeter for the International Linear Collider

Matthew Wing (DESY/UCL)

- **Introduction to the linear collider**
- **General design of the calorimeter**
- **Current understanding of the calorimeter concept - test beam and simulation**
- **Future R&D for CALICE-UK**

Introduction to the International Linear Collider

An e^+e^- linear collider is identified as the next priority for a large-scale collider facility. To use superconducting technology. Write detector TDR by 2009.

Will probe the high-energy range, $\sim 0.5-1$ TeV.

The “cleanness” of a LC will complement the LHC which is of much higher energy.

At a LC (as at most colliders), one wants to:

- Perform direct searches for new physics, e.g. supersymmetry.
- Make high precision measurements of fundamental parameters \rightarrow indirect searches for new physics, deeper understanding of e.g. the Higgs mechanism.

For such a program, far more advanced apparatus is needed than for current collider programs.

Higgs physics at a future linear collider

Old: $M_{\text{top}} = 174.3 \pm 5.1 \text{ GeV}$

$M_H = 96^{+60}_{-38} \text{ GeV}$

$M_H < 219 \text{ GeV (95% CL)}$

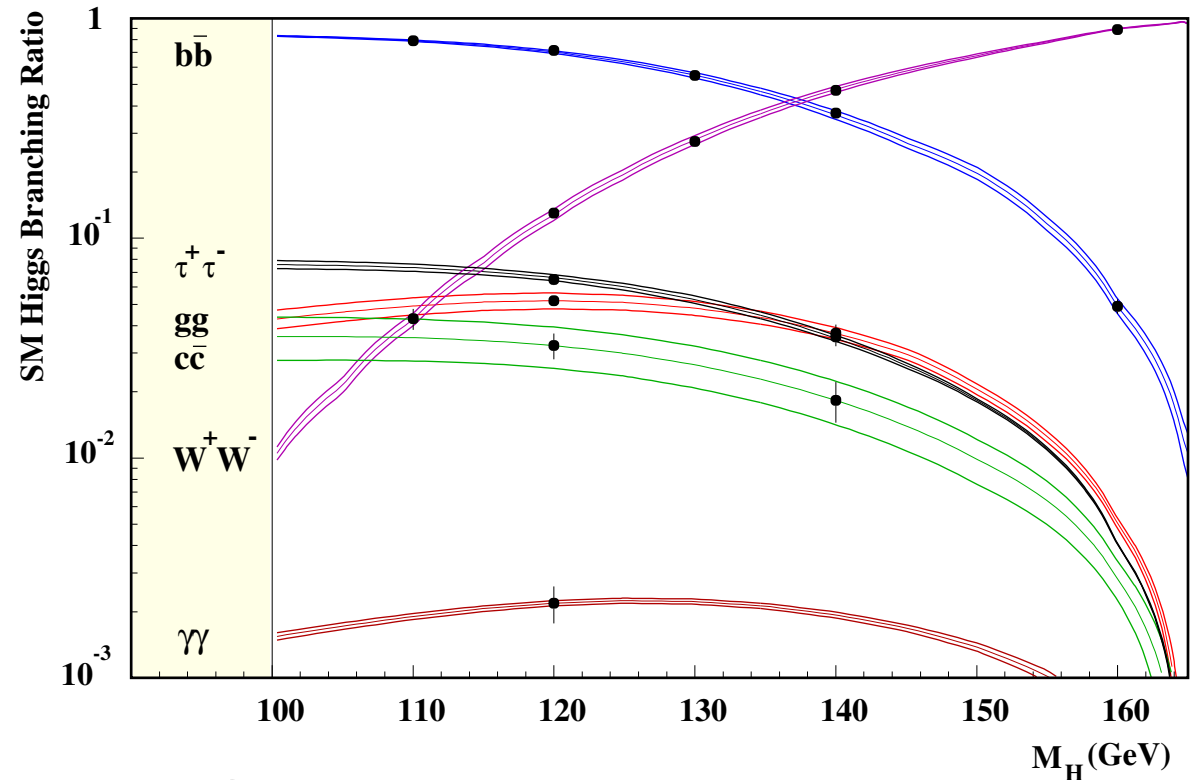
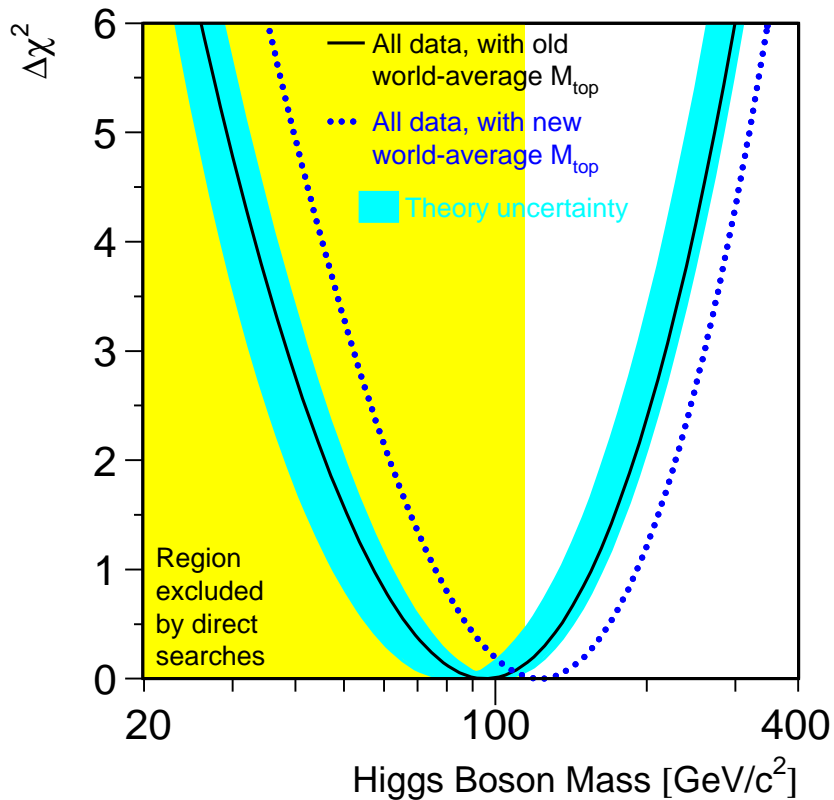

(Ref. TESLA TDR)

New: $M_{\text{top}} = 178.0 \pm 4.3 \text{ GeV}$

$M_H = 117^{+67}_{-45} \text{ GeV}$

$M_H < 251 \text{ GeV (95% CL)}$

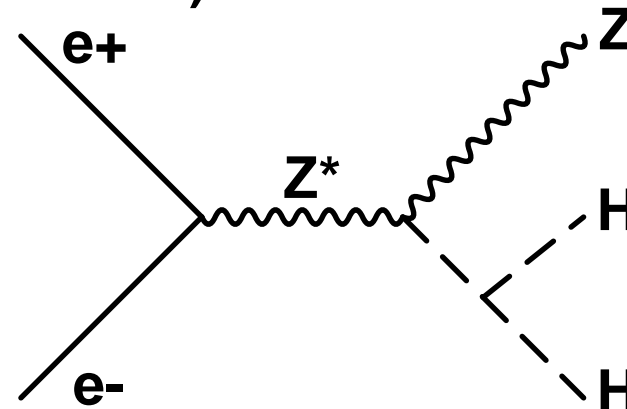

Supersymmetry at a future linear collider

(B. Allanach et al., hep-ph/0403133)

Particle	Mass (GeV)	δM_{LHC} (GeV)	$\delta M_{\text{LHC+LC}}$ (GeV)
\tilde{e}_R	143.9	4.8	0.05
\tilde{e}_L	207.1	5.0	0.2
$\tilde{\nu}_e$	191.3	-	1.2
$\tilde{\mu}_R$	143.9	4.8	0.2
$\tilde{\mu}_L$	207.1	5.0	0.5
$\tilde{\nu}_\mu$	191.3	-	-
$\tilde{\tau}_1$	134.8	5-8	0.3
$\tilde{\tau}_2$	210.7	-	1.1
$\tilde{\nu}_\tau$	190.4	-	-

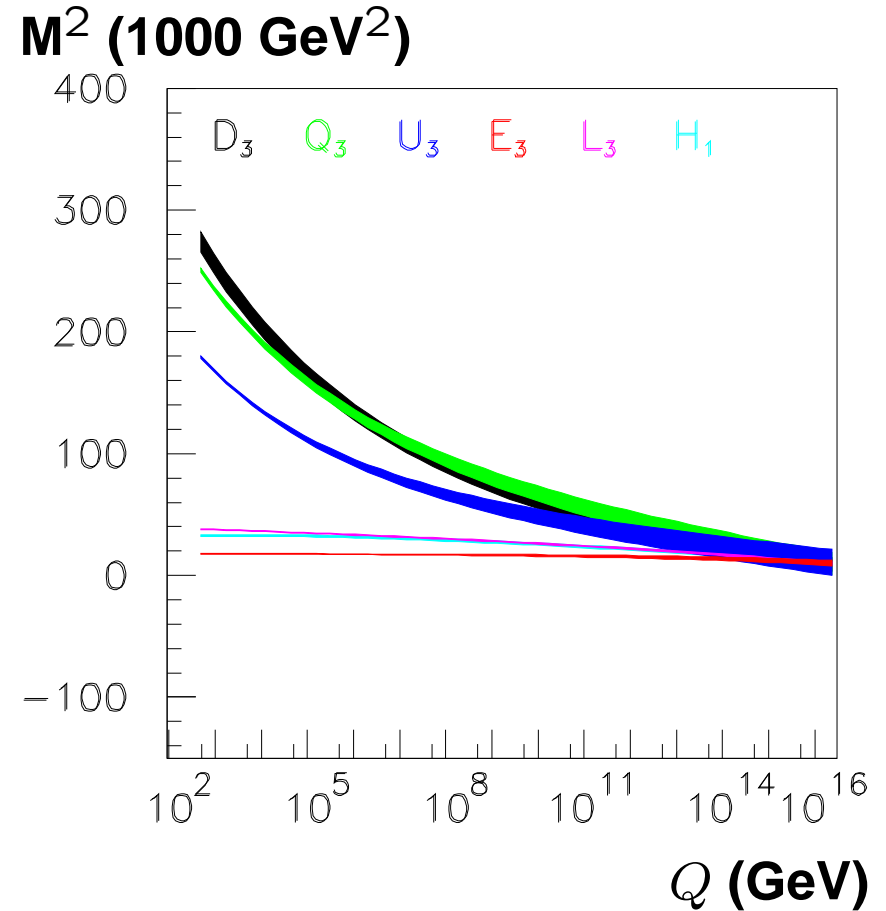

Other physics:

- Other models of supersymmetry
- Alternative theories, e.g. extra dimensions
- Precision electroweak and QCD

Building a linear collider in Hamburg

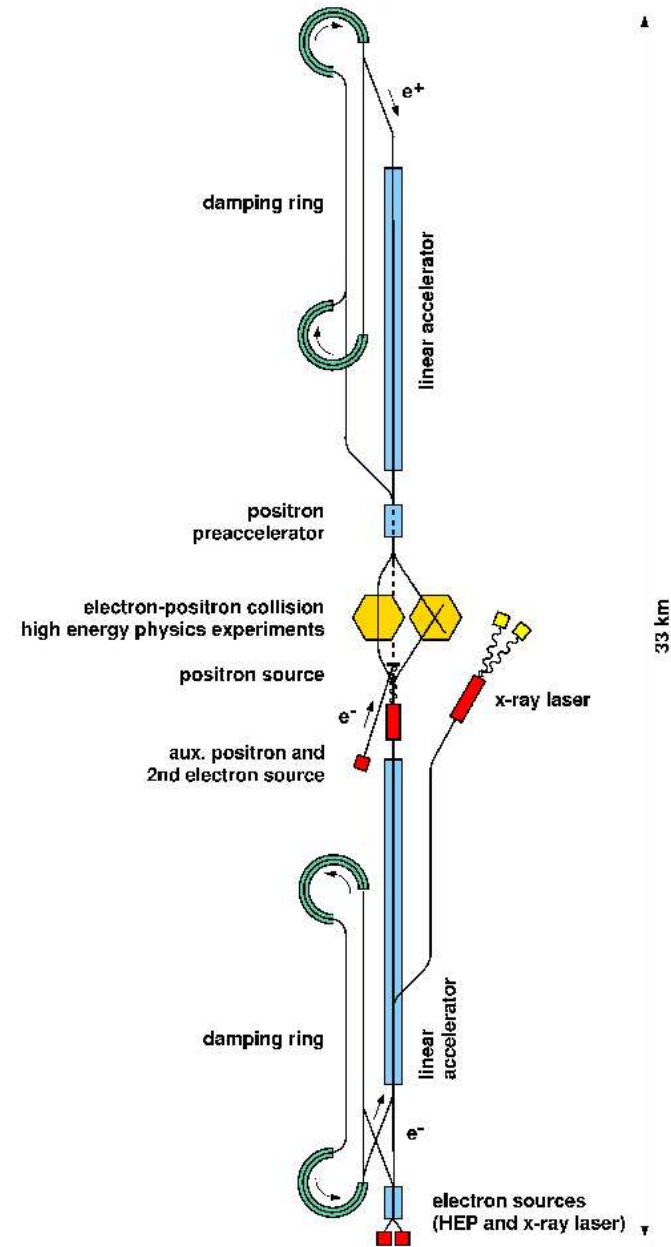
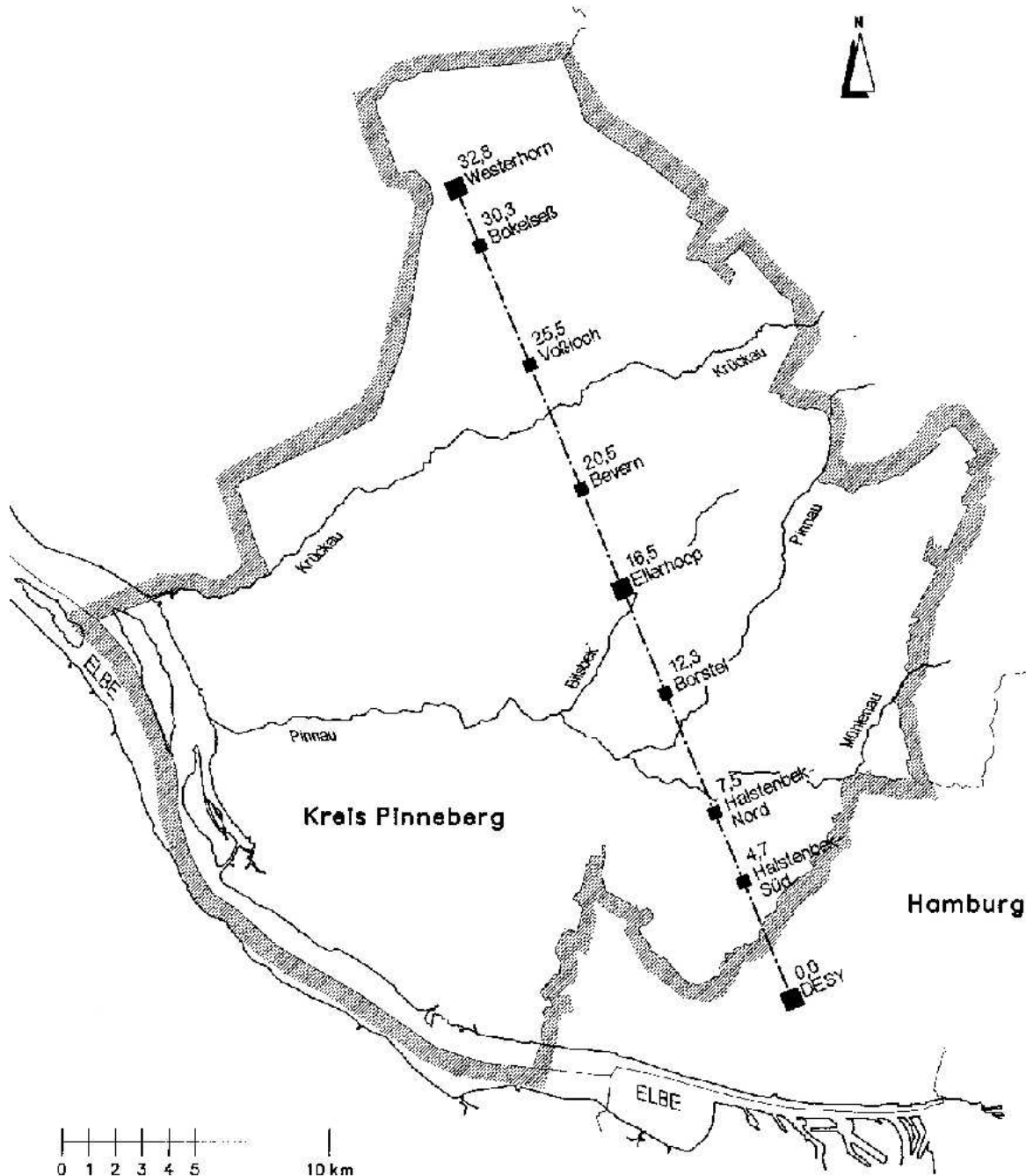

The challenge

Unprecedented high precision is needed:

Accelerator and beams; high (accuracy) luminosity, communication with detector and experiment.

Tracking and calorimetry with excellent resolution - high-mass particles, e.g. $t\bar{t}H$ will produce multiparton (eight) final states.

Calorimeter has high granularity, tracking volume large with high magnetic field.

Full angular coverage. NB. missing E_T is a signature for new physics.

Reconstruction of b and c quarks (and τ leptons) using a vertex detector.

The TESLA detector

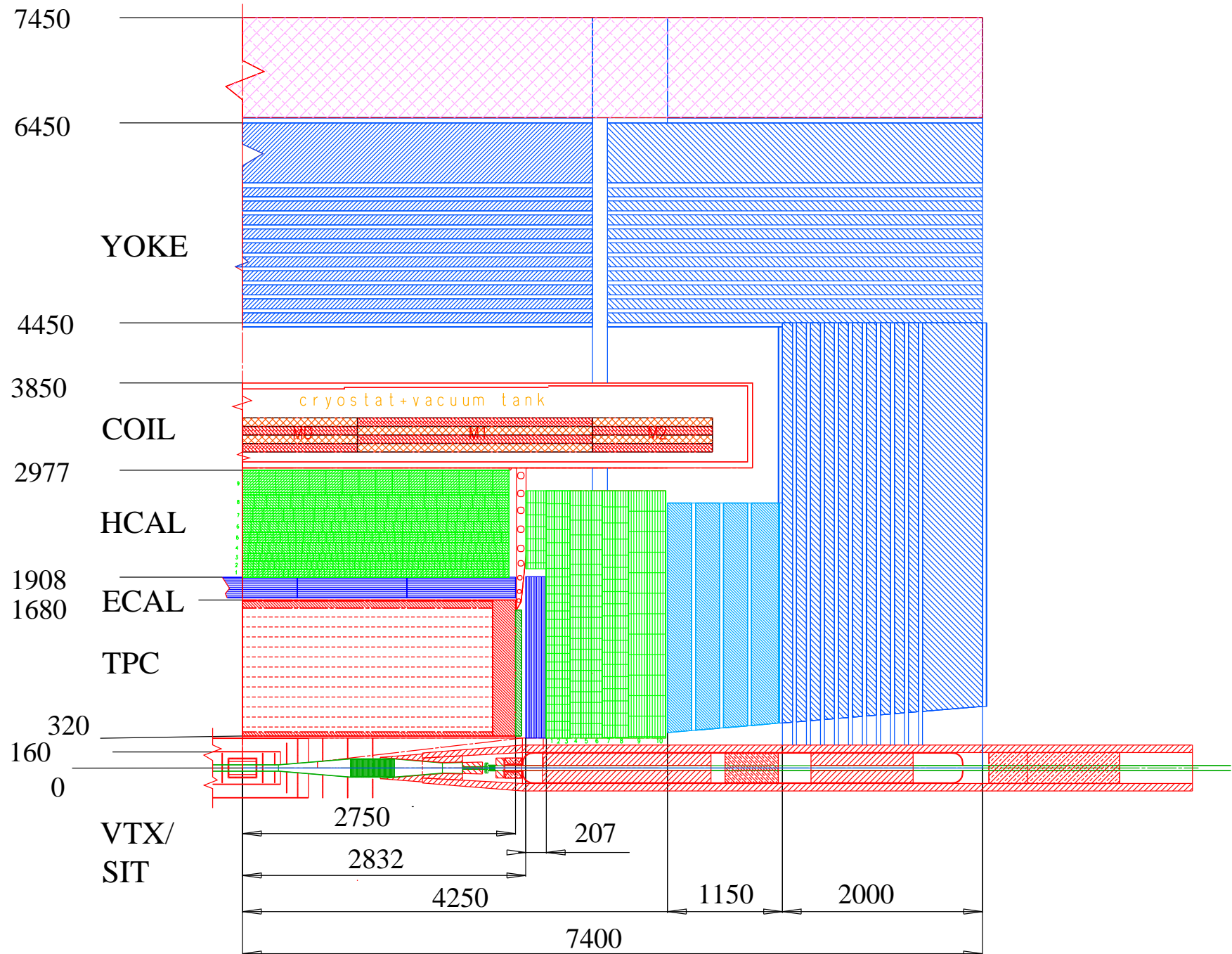

Detector requirements, e.g.

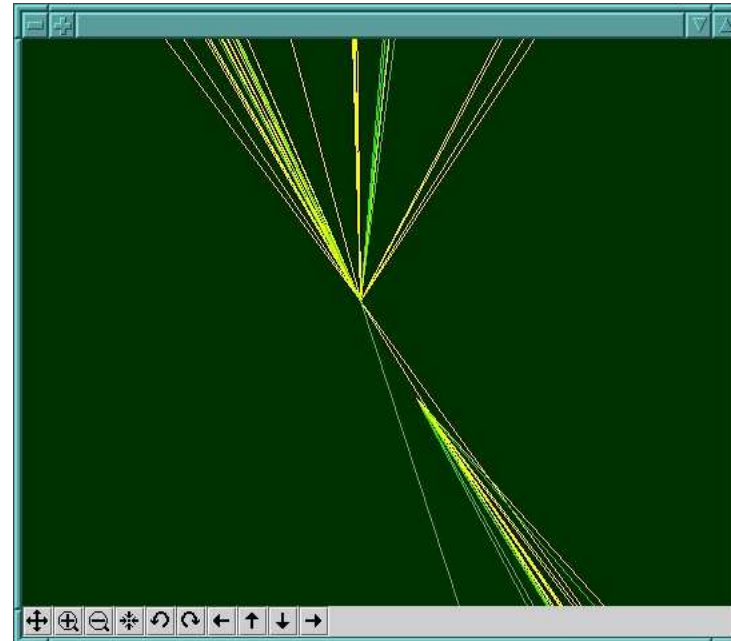
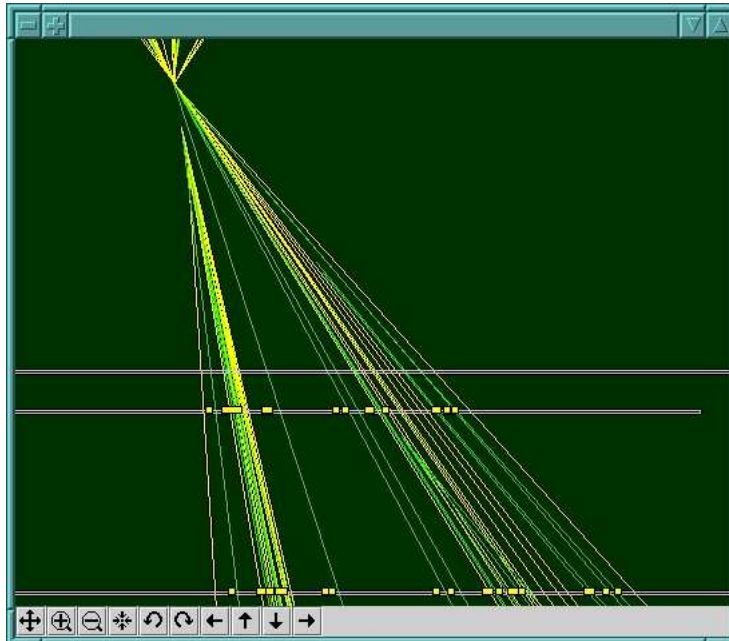
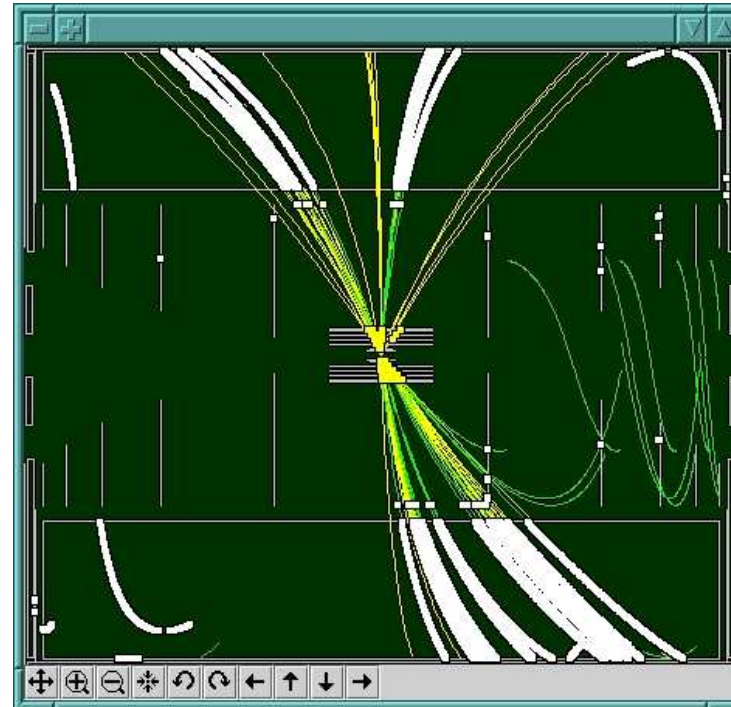
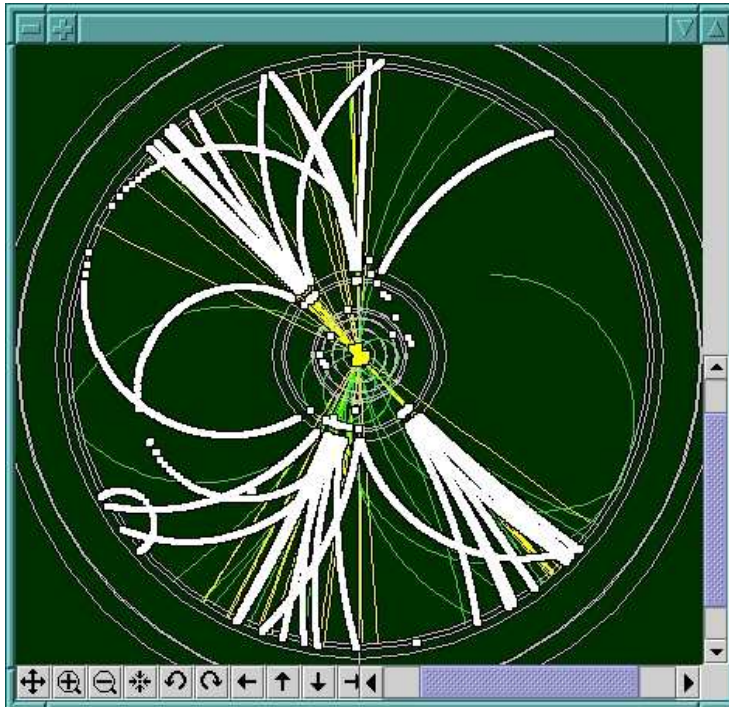

CALICE Calorimeter

The calorimeter

CALICE is a collaboration of 167 physicists from 26 institutes, from Europe, US and Asia. CALICE-UK: Birmingham, Cambridge, Imperial, Manchester, RAL and UCL. RHUL to join.

Focus on high granularity, optimised for energy flow.

ECAL: Si-W with $1 \times 1 \text{ cm}^2$ pads and up to 40 layers

Analogue HCAL: Scintillating tiles ($\geq 3 \times 3 \text{ cm}^2$) and Fe

Digital HCAL: $1 \times 1 \text{ cm}^2$ cells - RPCs or GEMs

“Semi-digital” HCAL

A tracking calorimeter

Truth



Reconstructed

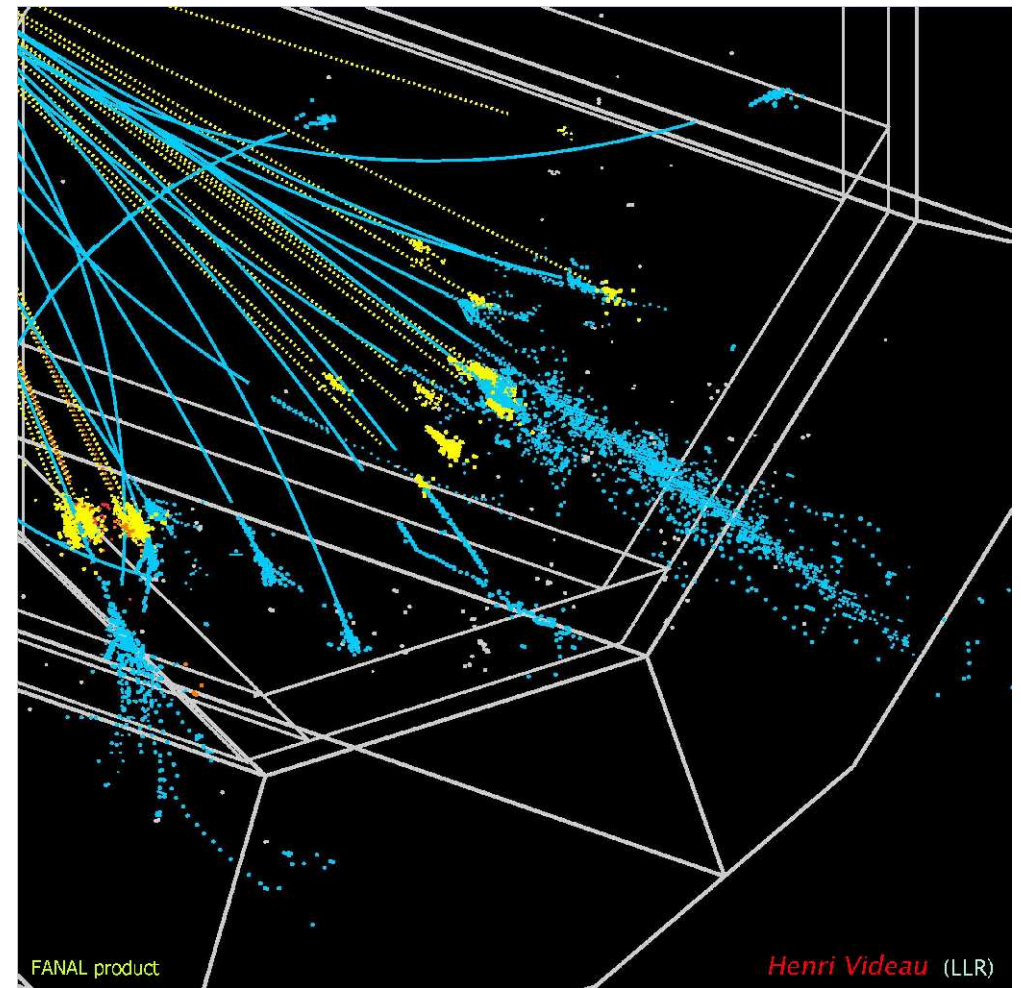
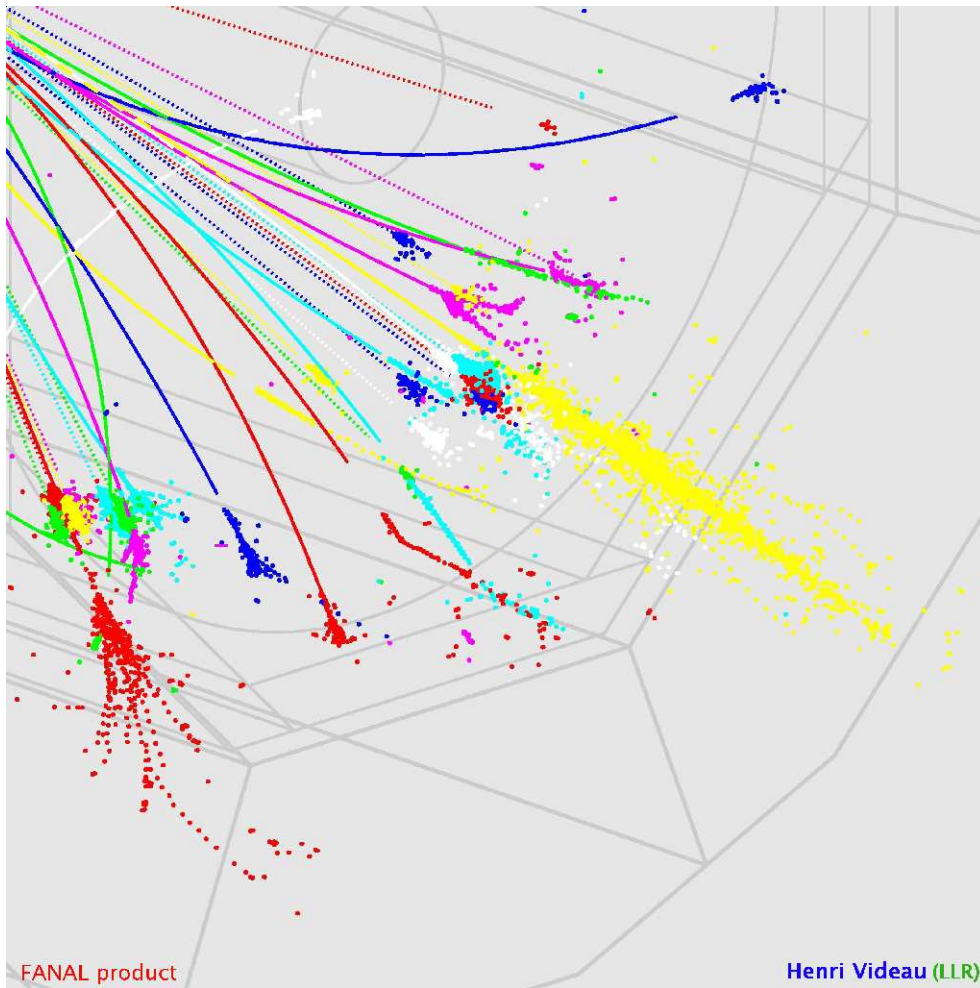

A high-resolution calorimeter

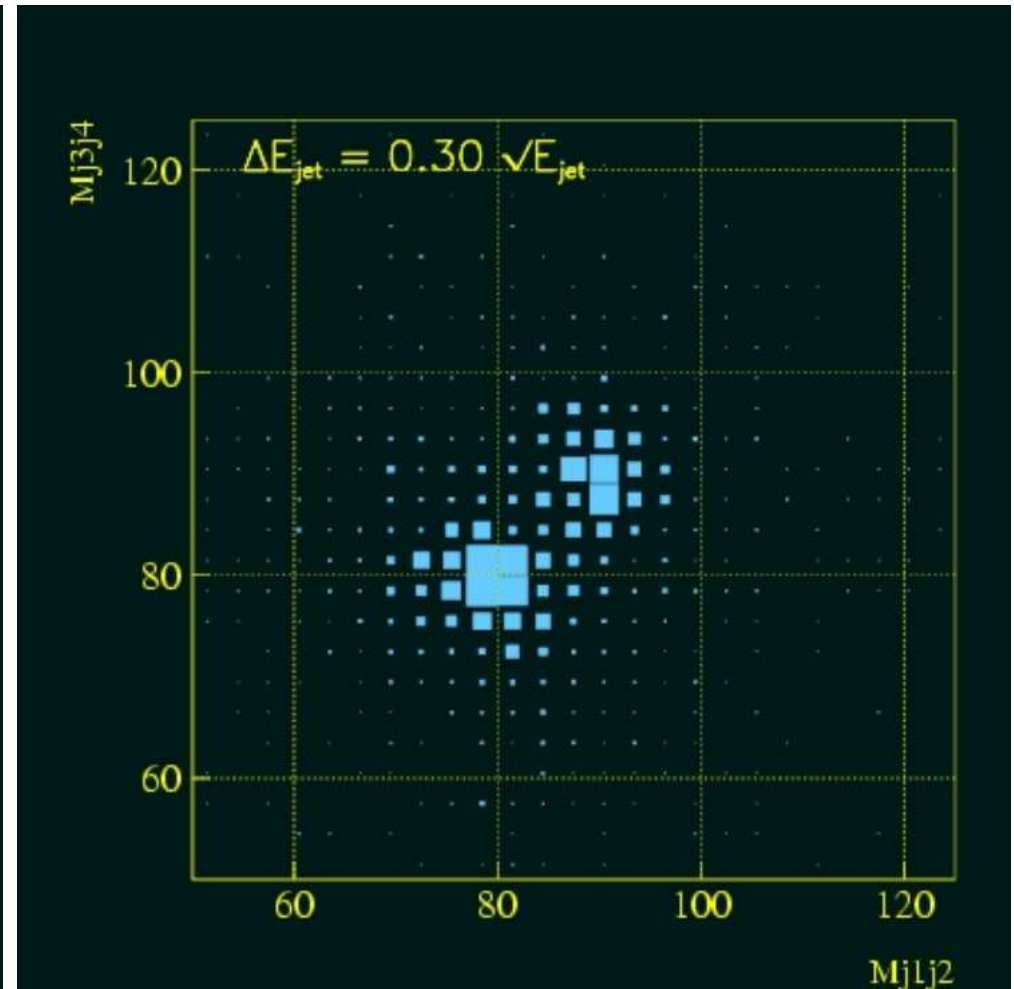
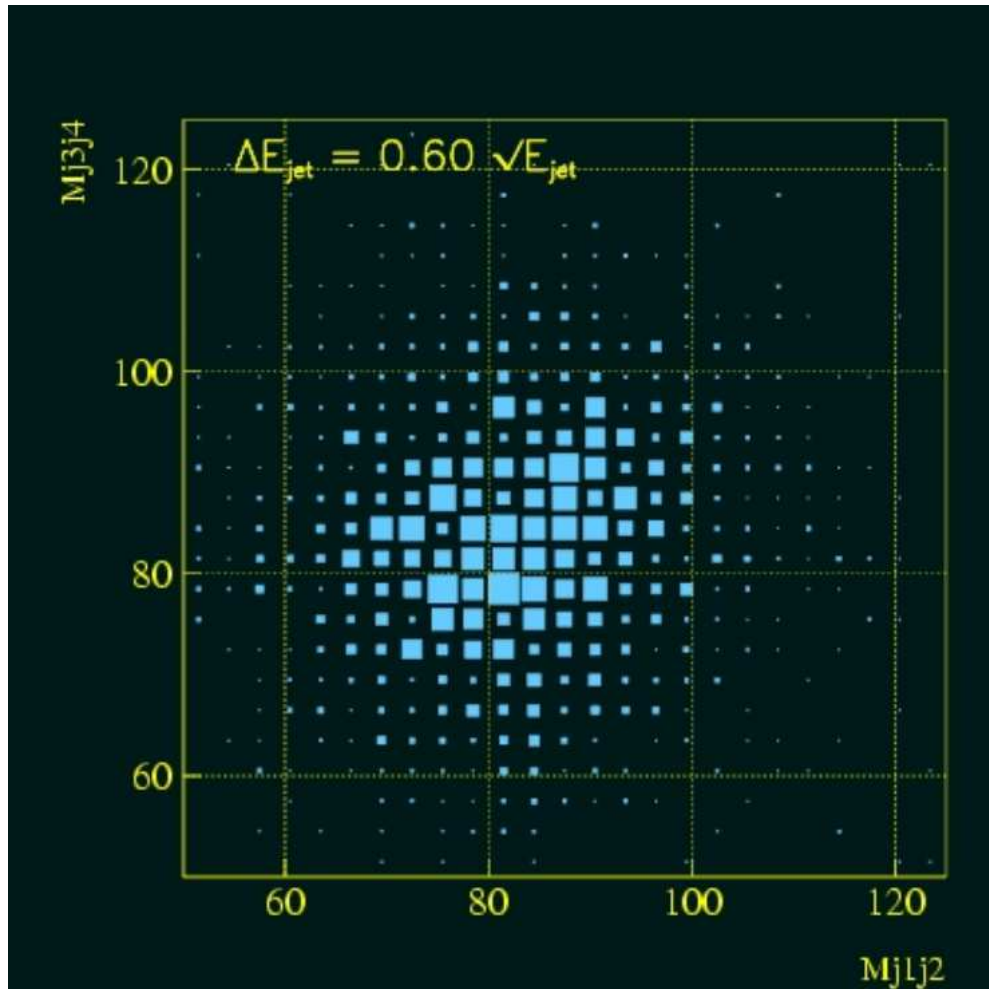

ZZ/WW discrimination in calorimeter

Layout of calorimeter

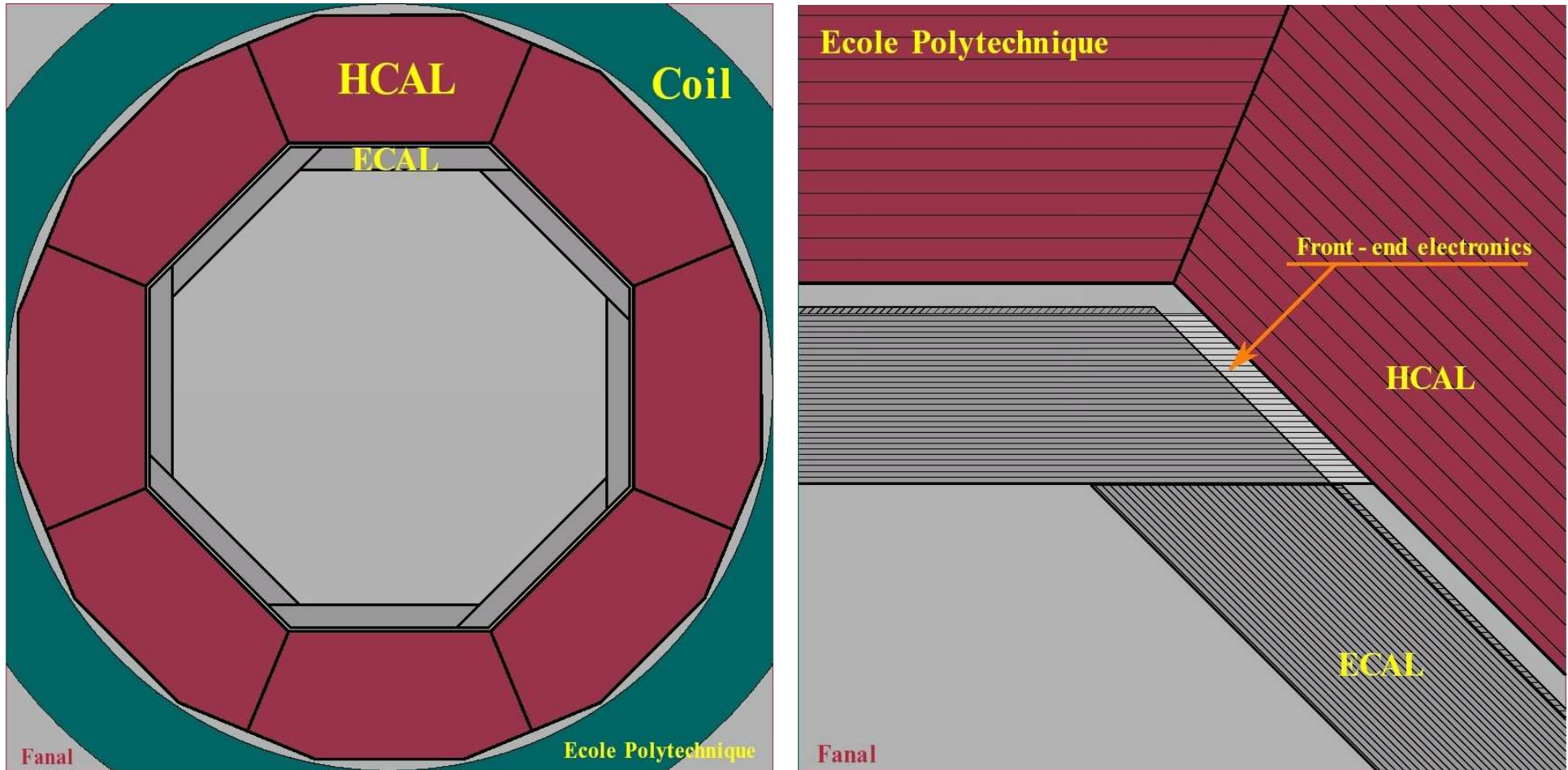

6000 slabs, length 1.5 m, each containing 4000 silicon pads.

Layout of calorimeter

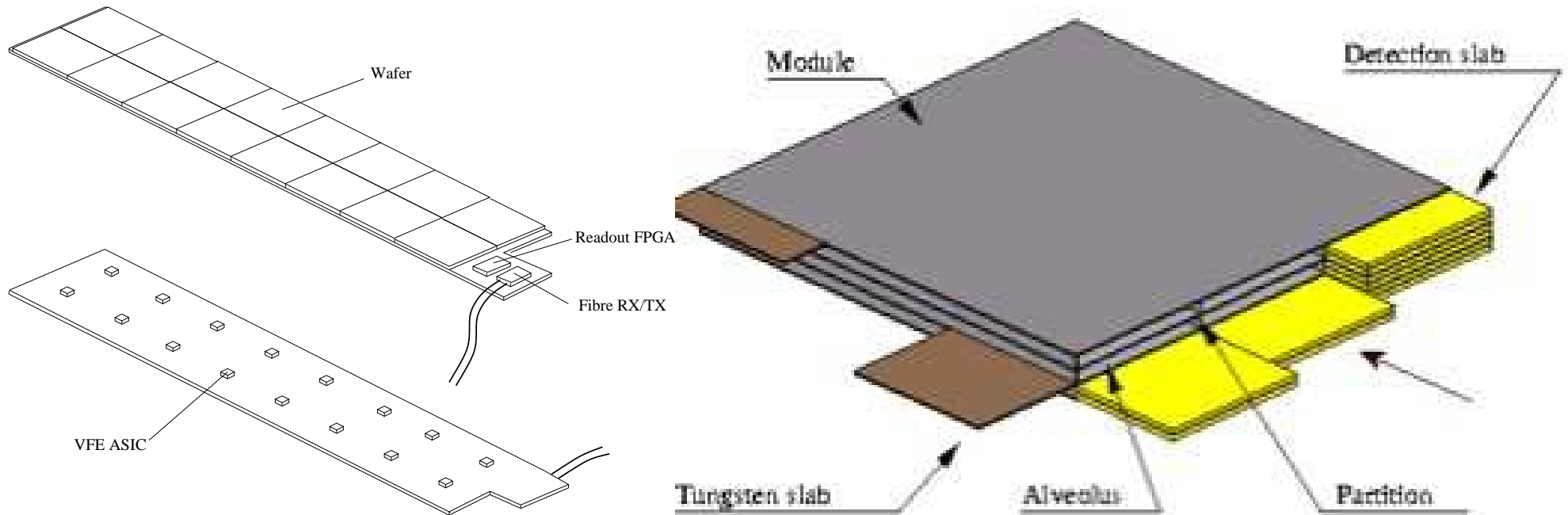

Very-front end (VFE) chip to provide shaping and digitisation and send data to front-end (FE) FPGA where zero-suppression is performed and data sent off the detector.

Calorimeter modelling

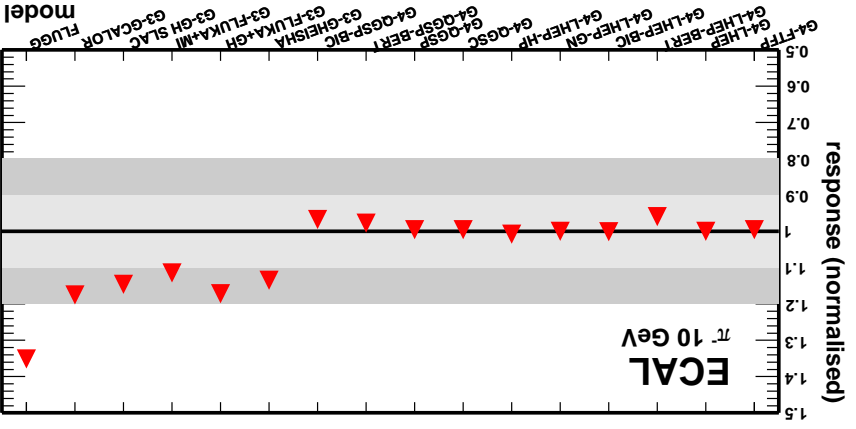
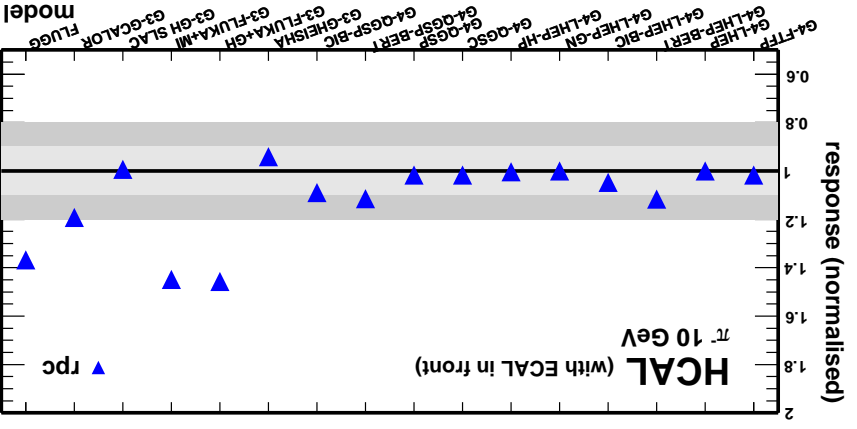
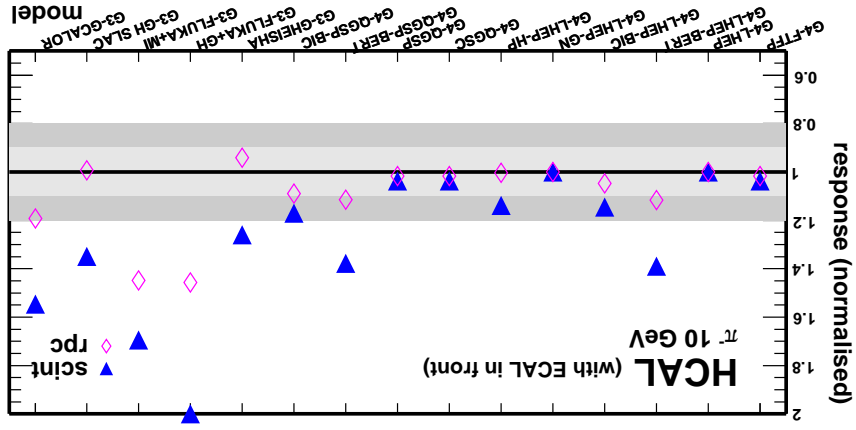
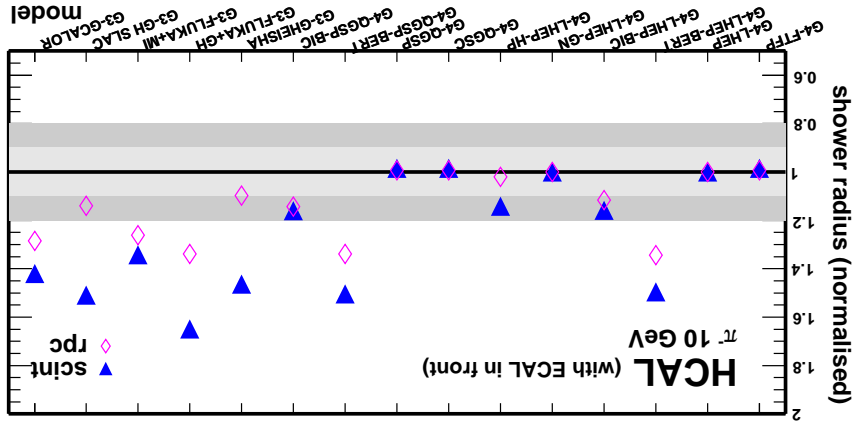

Need for test-beam data

Calorimeter pre-prototype

CALICE-UK contribution: electronics

Calice Readout Card (based on CMS tracker front-end driver board).

Receives analogue data from up to 96 ASICs, digitises and buffers up to ~ 2000 events.

AHCAL plan to use CRCs as well.

First cosmic tests in December 2004.

MIP peak seen above pedestal, $S/N \sim 9:1$.

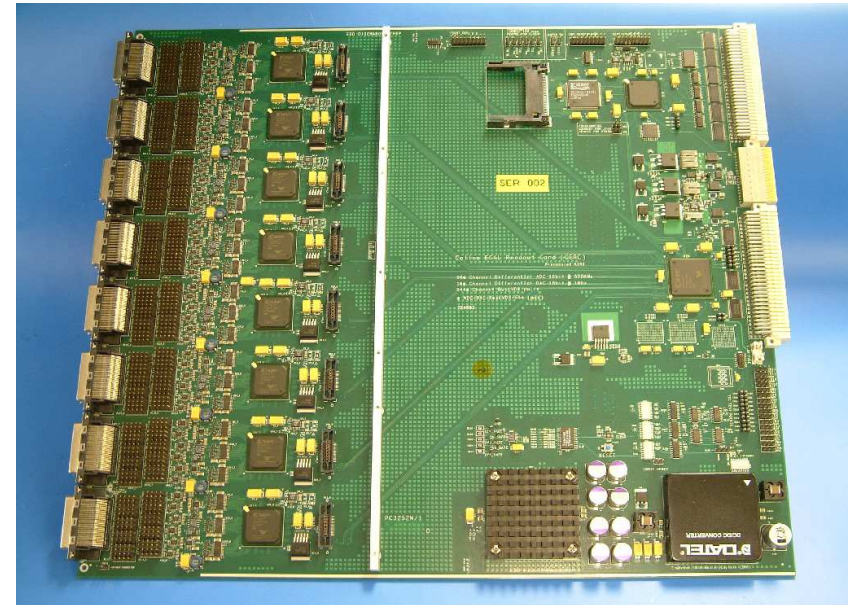

ADC values for neighbouring hits

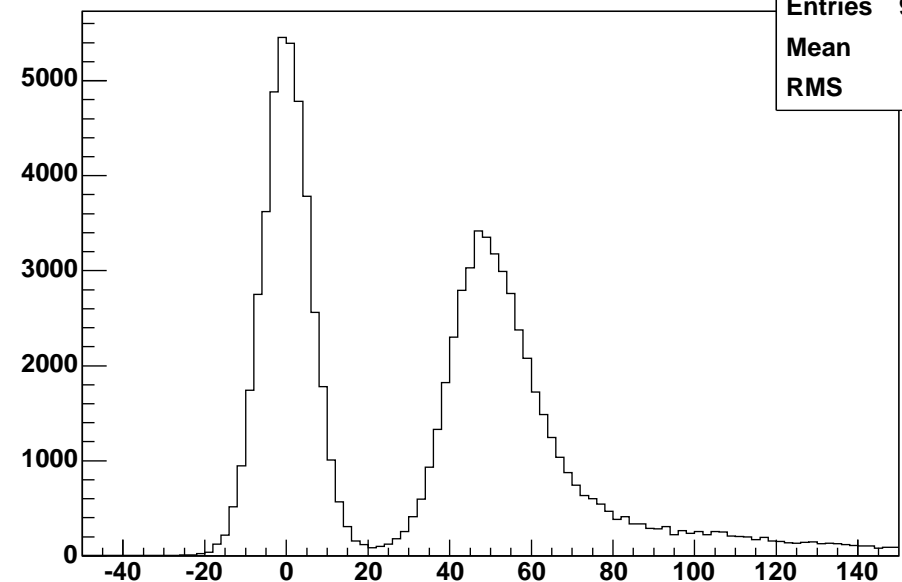

Cosmic muon

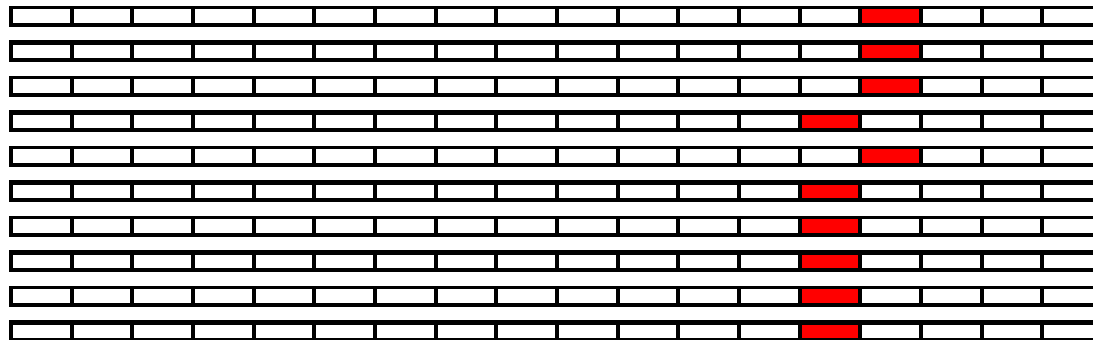
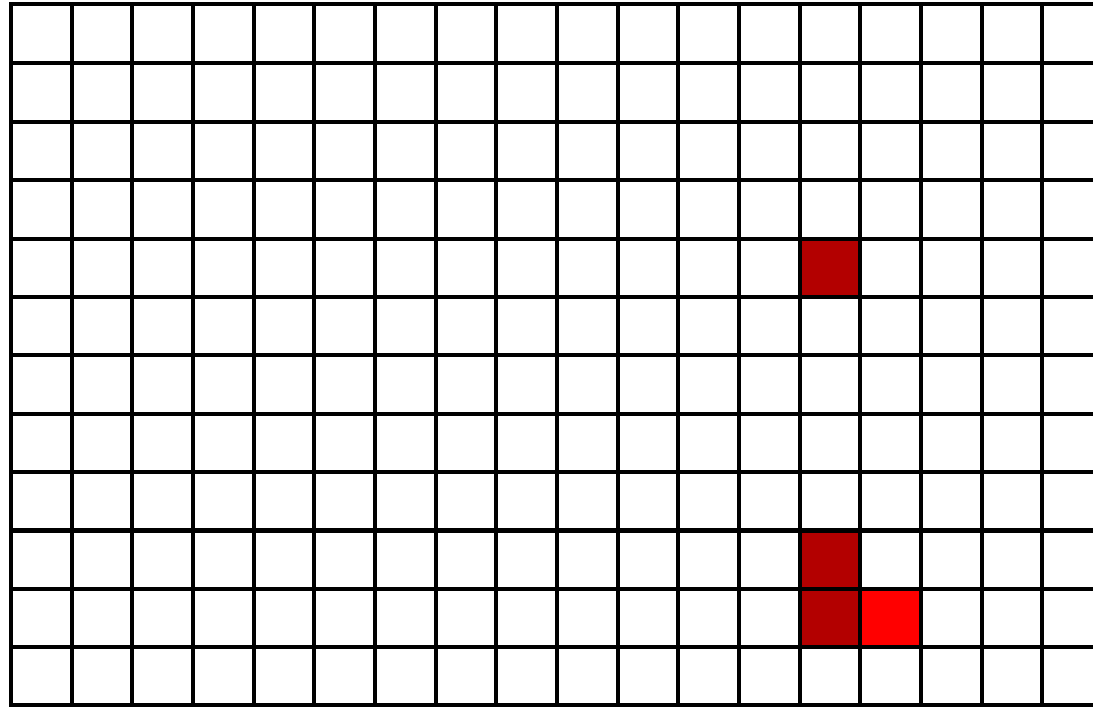
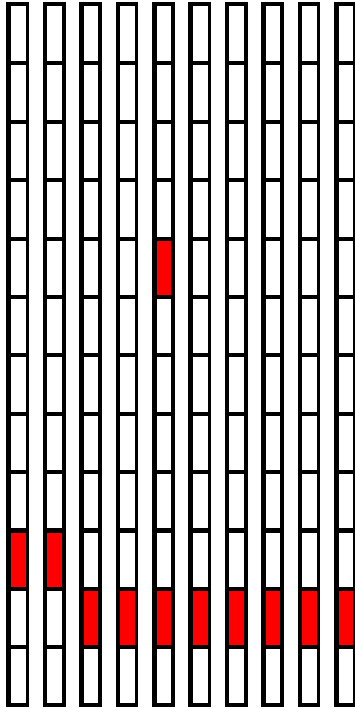

RcdHeader::print() Record Time = 18:23:03:436:957 Fri Dec 17 2004, Type = 5 = event

DaqEvent::print() Event numbers in run 37, in configuration 37, in spill 37

Structure of ECAL pre-prototype

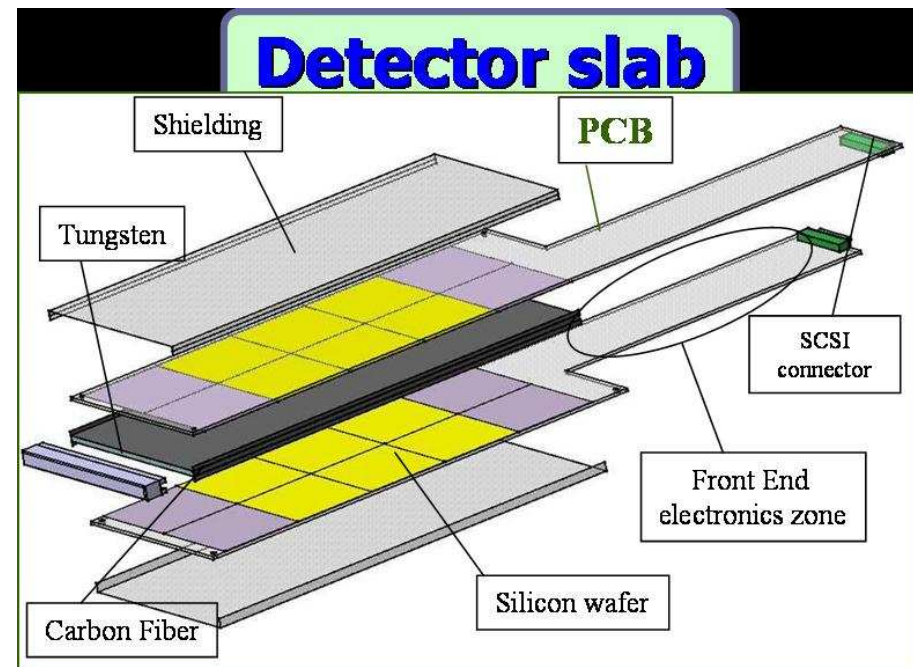
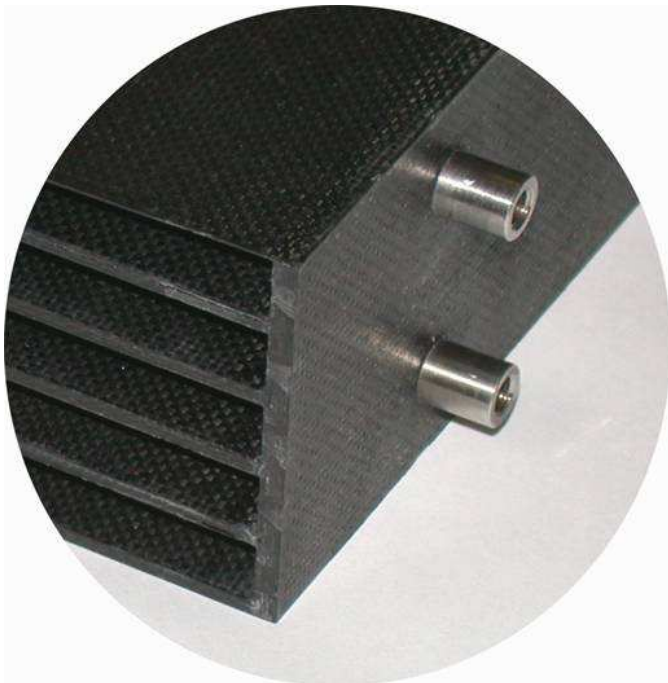
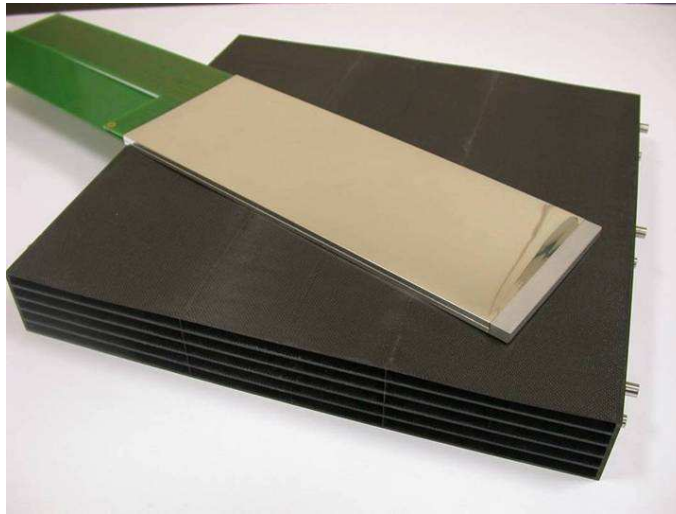

Calorimeter in test beam in DESY



Electron beam event

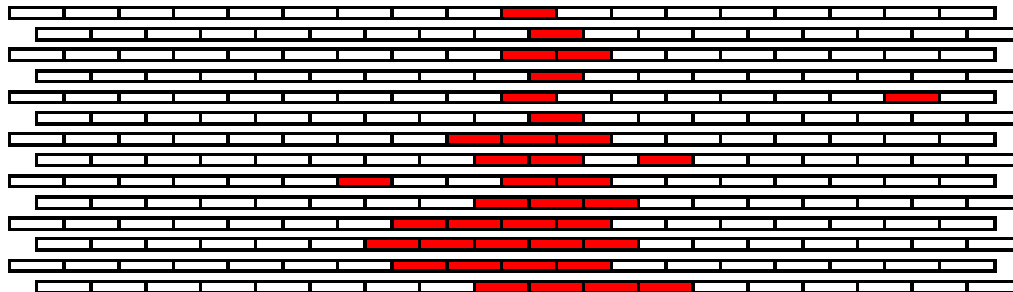
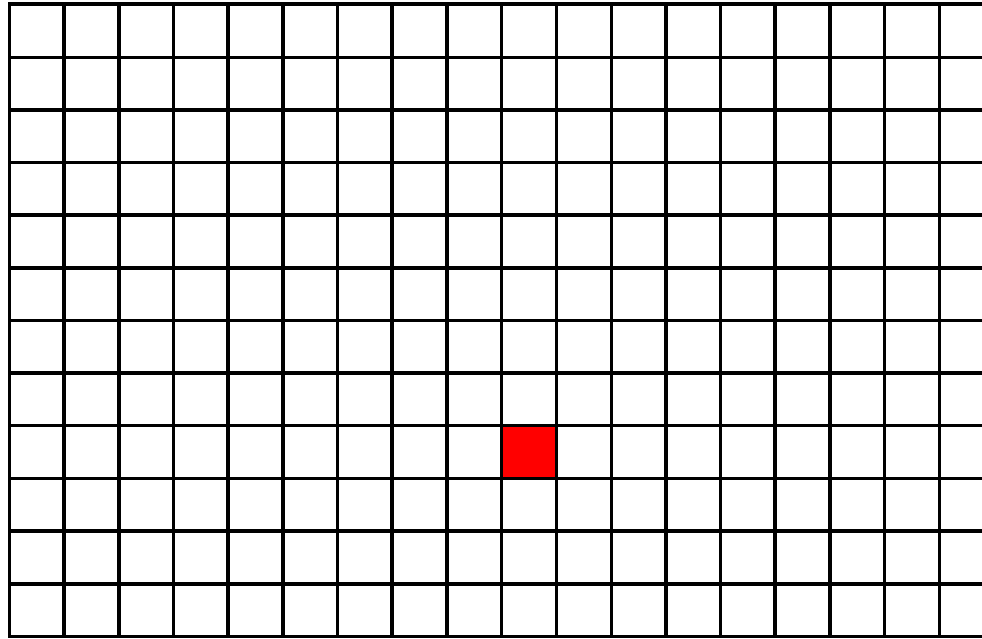
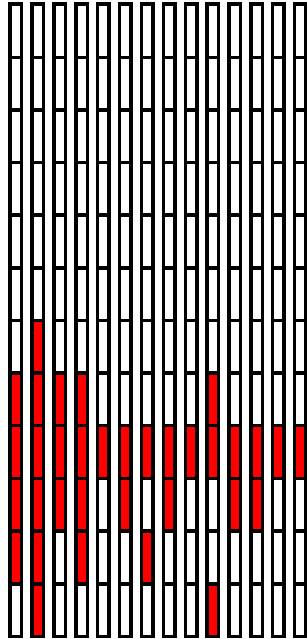

RcdHeader::print() Record Time = 15:54:23:784:456 Tue Jan 18 2005, Type = 5 = event

DaqEvent::print() Event numbers in run 0, in configuration 0, in spill 0

Test-beam events

Run 100082 Event 102

RcdHeader::print() Record Time = 11:02:16:744:353 Fri Jan 28 2005, Type = 5 = event
DaqEvent::print() Event numbers in run 0, in configuration 0, in spill 0

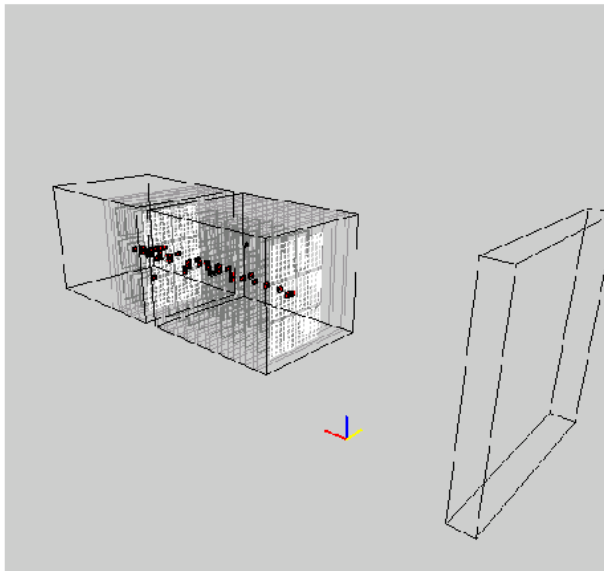
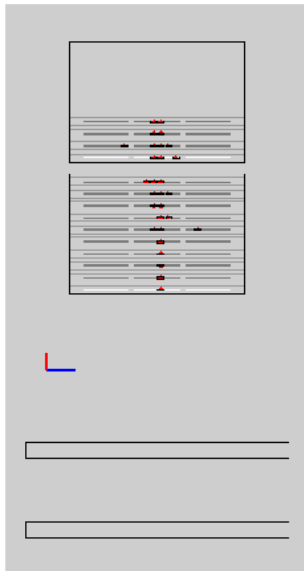
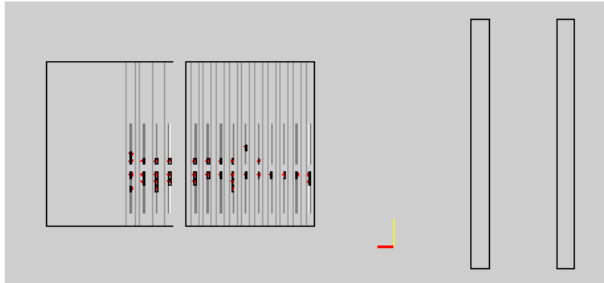
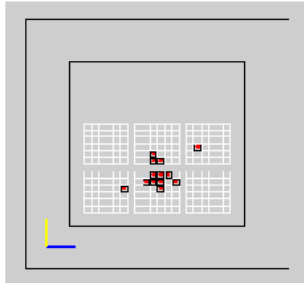

Run 100082 Event 103

RcdHeader::print() Record Time = 11:02:16:794:648 Fri Jan 28 2005, Type = 5 = event
DaqEvent::print() Event numbers in run 0, in configuration 0, in spill 0

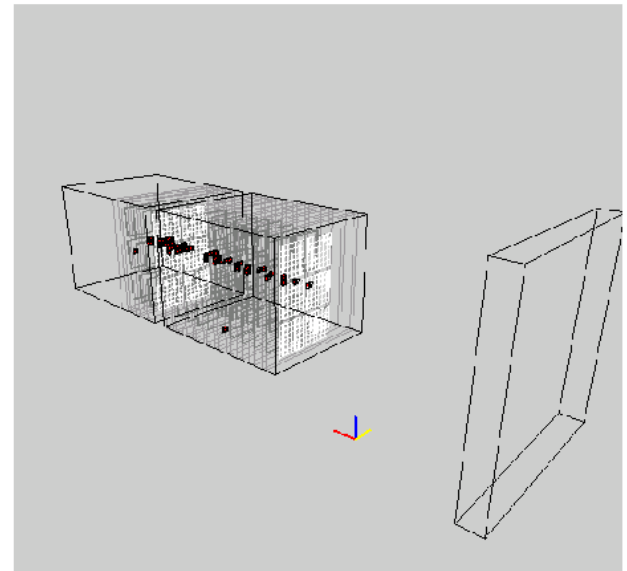
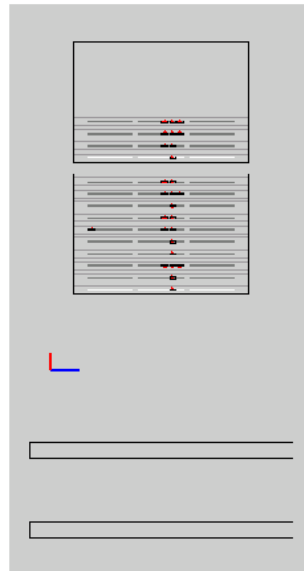
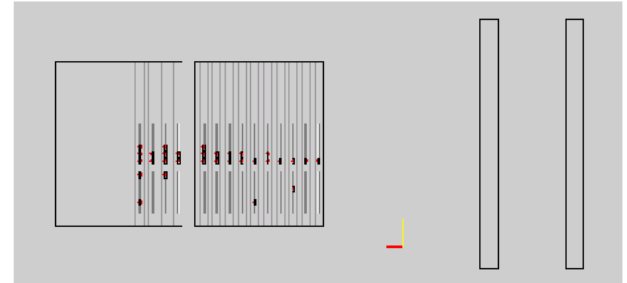
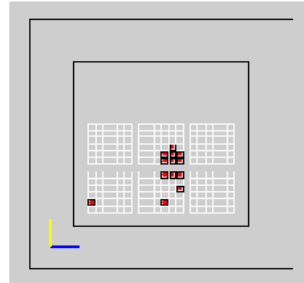

Test-beam plans

Pre-prototype ECAL installed in DESY since January for test beam running; electrons (1–6 GeV).

- **DAQ built by UK hooked up to layers taking data.**
- **14 layers of silicon in January.**
- **30 layers in April and run until July.**

Move to Fermilab (MTBF) in September with AHCAL and DHCAL for hadron beams; protons (<120 GeV), others (5–80 GeV) + electrons.

Exposure of ECAL to hadron beams shown to have worthwhile sensitivity to hadron models.

AHCAL to Fermilab in November 2005, run until mid-2006. DHCAL anticipated in 2006-7.

Future R&D

Future R&D

Bid to PPRP on 2 February 2005:

- **WP1: Completion of test-beam programme**
- **WP2: Data acquisition**
- **WP3: Monolithic active pixel sensors (MAPS)**
- **WP4: Mechanical and thermal studies**
- **WP5: Simulation and physics.**

Test-beam and simulation

- **Complete test-beam programme; maintenance of DAQ electronics, taking and analysing data.**

Use test-beam data and previous simulation work to have an impact on global design studies:

- **Energy-flow algorithms - flexible, generic for comparison between detector designs.**
- **Global detector design - impact decisions on key detector issues (technology, dimensions, etc.).**
- **Support for other workpackages.**
- **Physics studies - establishing benchmark analyses for design issues.**

Jet in a Z event

Truth



Reconstructed

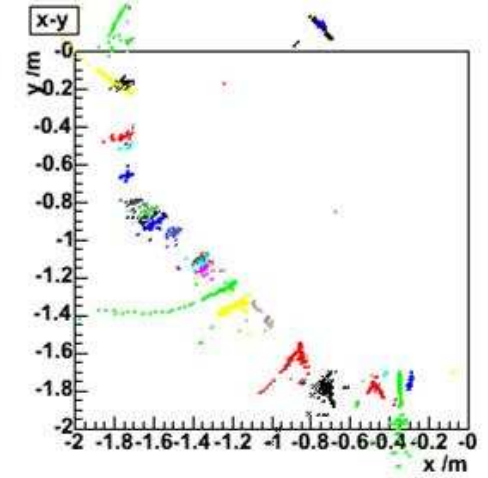
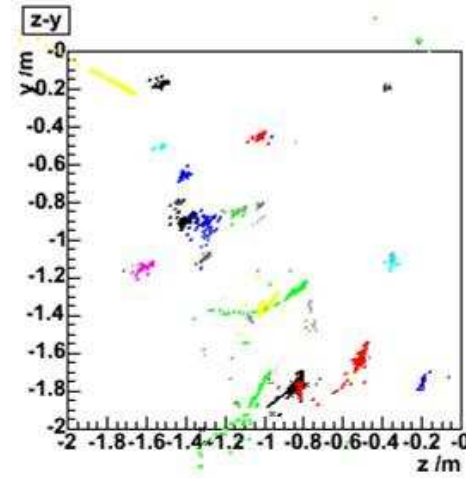
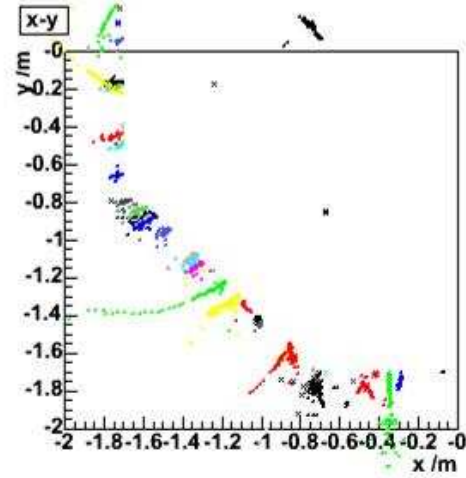
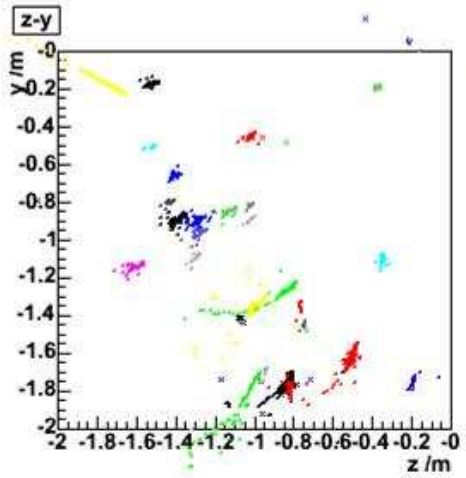
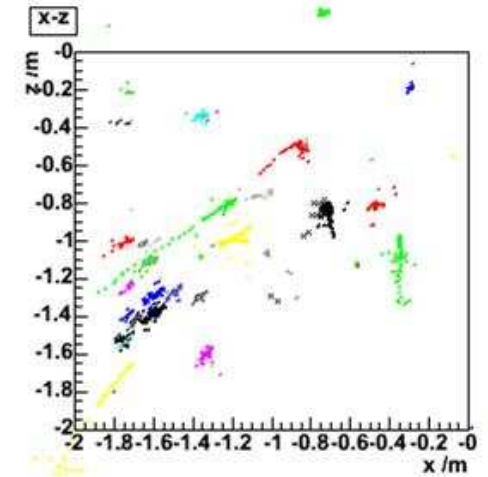
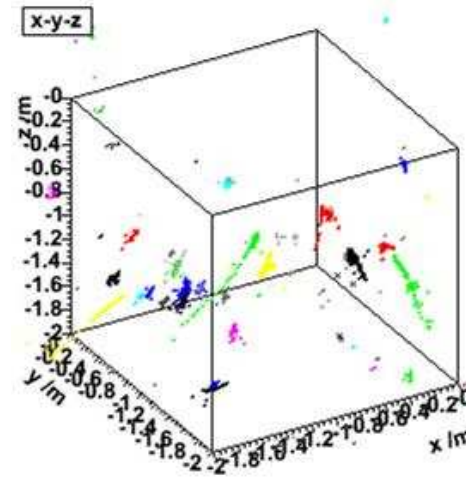
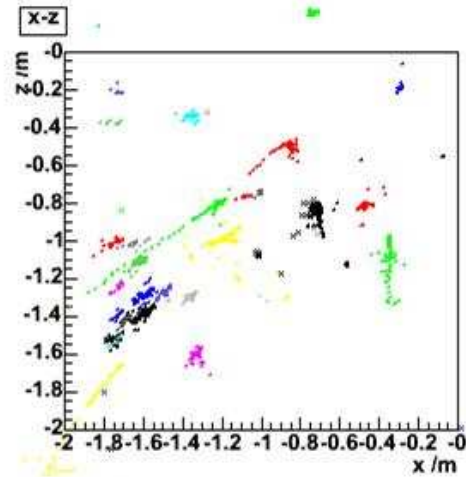
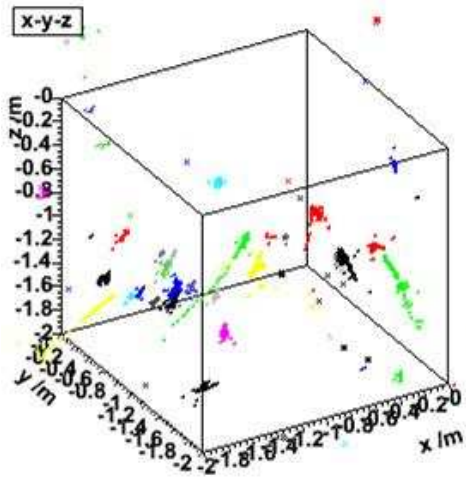

Data acquisition

Will be able to build an ECAL DAQ system, but challenging issues exist:

- **Plan is NOT to build DAQ system now.**
- **Maintain and extend our current leadership to build it for full prototypes and final system.**
- **Have designed the DAQ concept and identified bottlenecks in the system.**
- **Some of the R&D could lead to radical changes in the calorimeter (and global detector) design.**
- **Try and do R&D generic enough for, e.g. MAPS, different number of channels, etc..**
- **Use commercially available products instead of traditional use of bespoke apparatus.**

Data acquisition system - general concept

In ECAL, 24 million channels and TESLA design of 4886 bunches, each crossing every 176 ns. So 1 ms interactions, 200 ms downtime.

Assuming 2 bytes per pad per sample: raw data is $24 \cdot 10^6 \times 4886 \times 2 = 250$ GB

For ASICs with 32 – 256 channels, have 0.3 – 2.5 MB per ASIC and within a bunch train, 0.4 – 3 GB/s to be transported. Take as 1 GB/s

- **Data transportation from ASICs to front-end electronics.**
- **Shipping data off detector to receiver.**
- **Structure of off-detector receiver.**

Data acquisition system - related to VFE

Expect zeroth VFE chip design in 1-2 years - provide DAQ

Readout MAPS design

Final DAQ should be able to readout ECAL and HCAL - coordinate convergence of ideas.

Do not expect full 1.5 m prototype on this timescale:

- Build 1.5 m slab with FPGAs connected to test data transfer.
- CAD modelling and bench testing
- Noise, interference, power issues, space between layers.

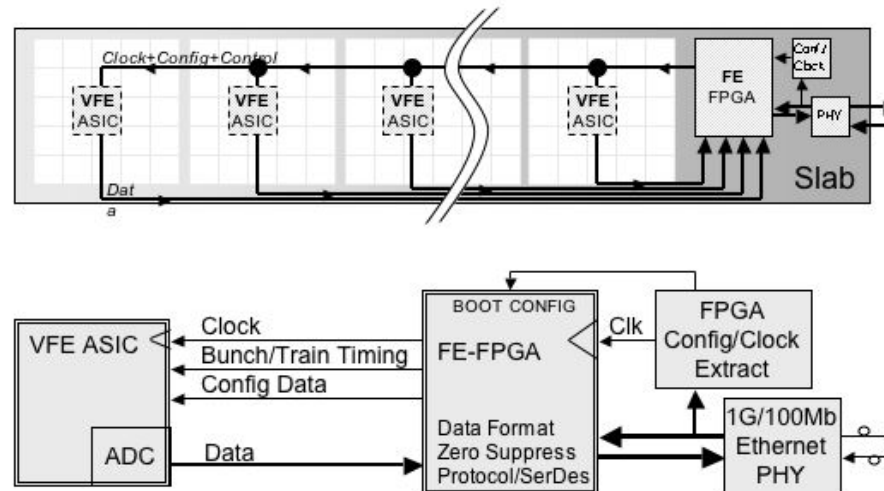

Possible network technologies

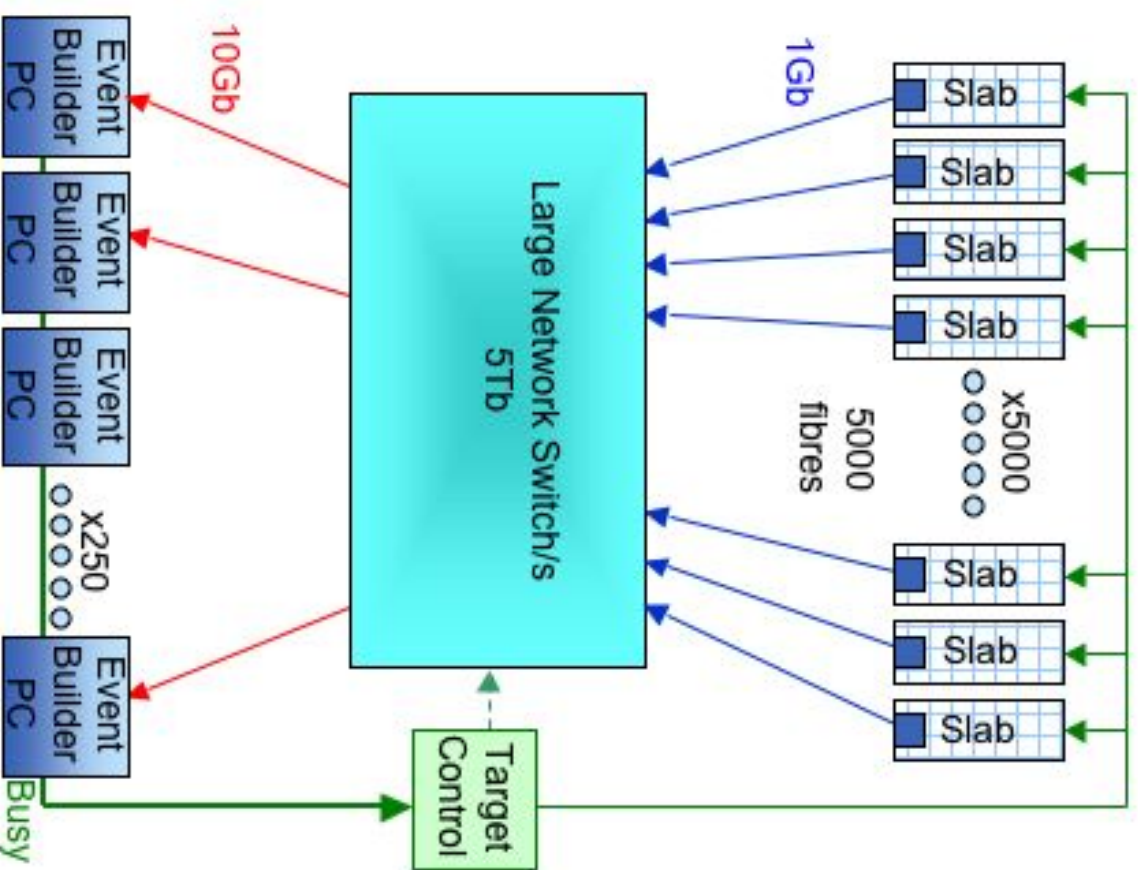
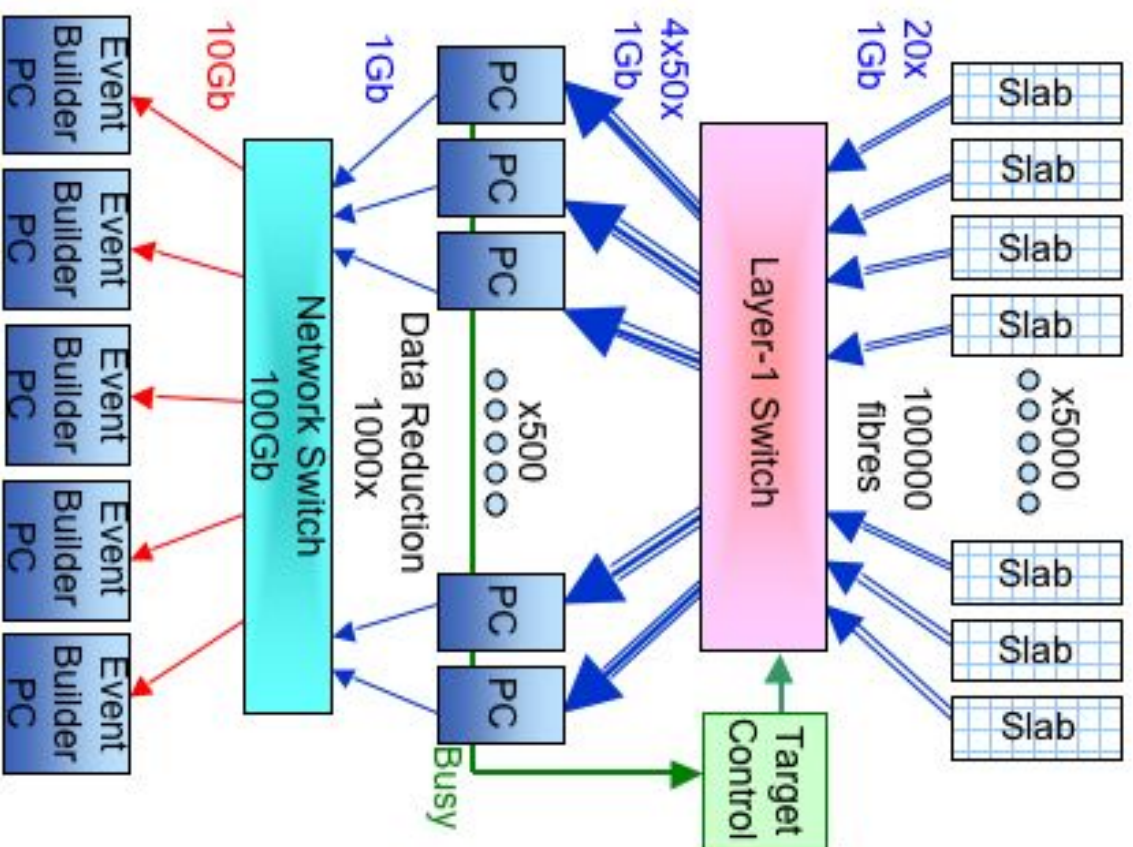

Off detector

Start offline reconstruction in the DAQ - ideally have all of ECAL in one PC, but more likely many.

Local clustering in several PCs; simulate and test system.

Test system contains PCI receiver card which controls clock and control.

Many cards per PC and many lanes (PCI Express) per card.

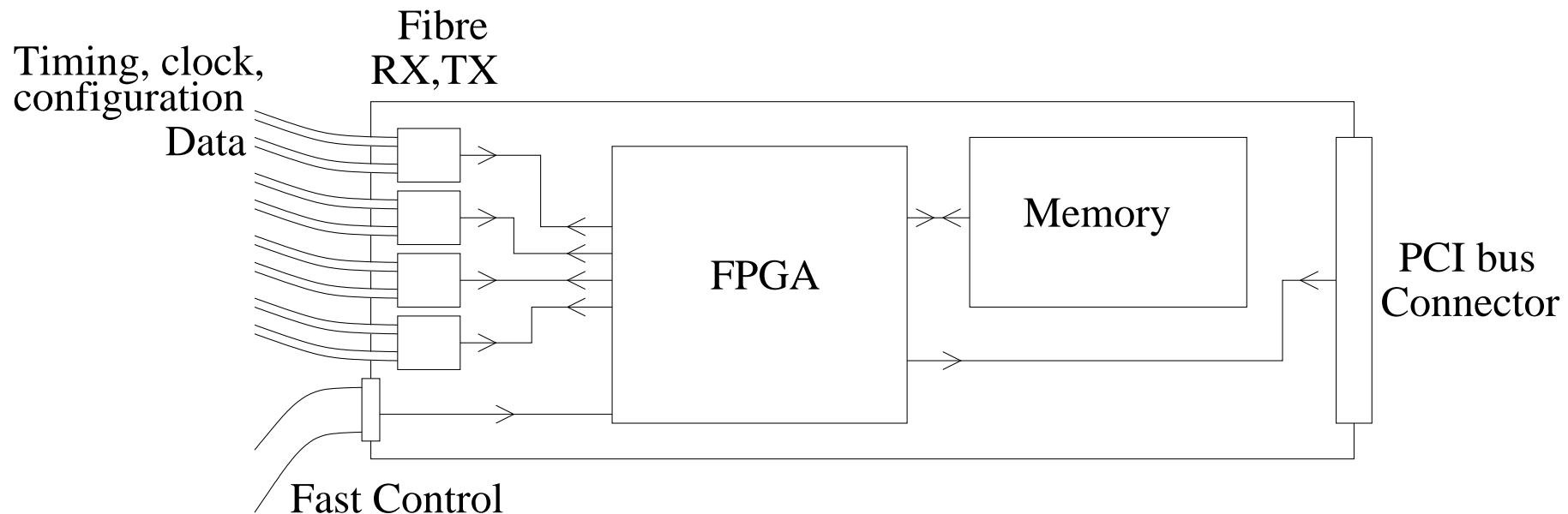

MAPS - a new design

Considering alternative technology which may be cheaper.

Instead of using conventional silicon diodes, use Monolithic Active Pixel Sensors (MAPS).

Readout integrated into the MAPS - no need for separate chip.

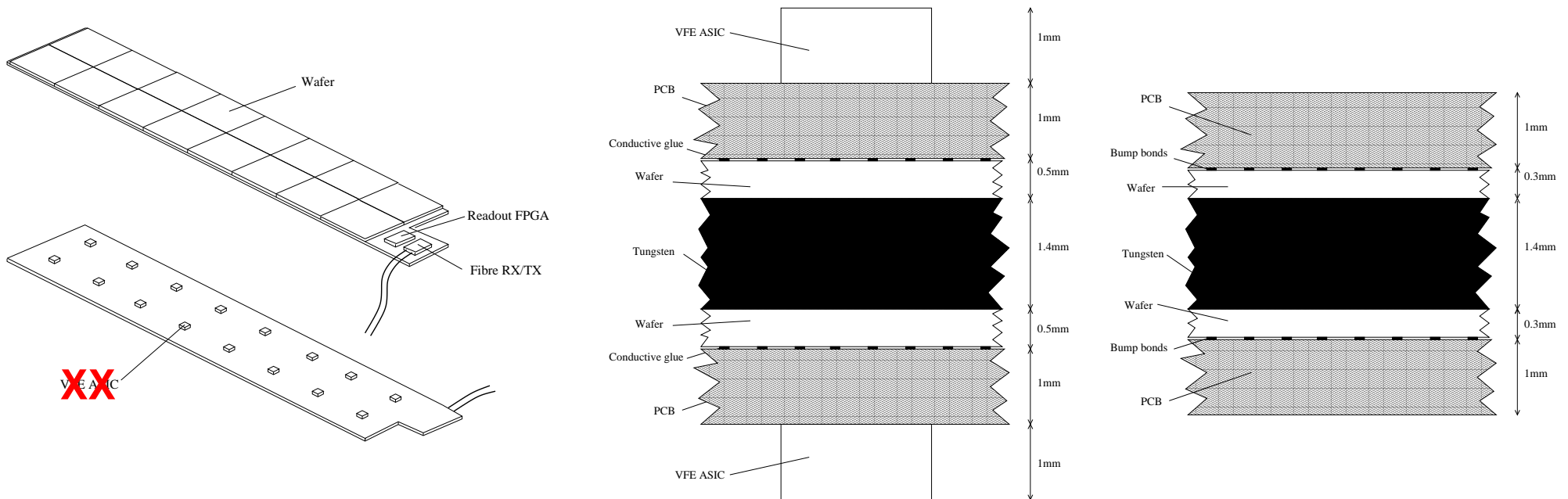

Pixel size $50 \times 50 \mu\text{m}^2$. Binary decision - effective digital ECAL.

MAPS - advantages

Pixel size $50 \times 50 \mu\text{m}^2$. Binary decision - effective digital ECAL.

Due to finer granularity, improved two cluster separation - endcaps?

No VFE chip on silicon, so reduced spacing between layers:

- **Reduced Molière radius, i.e. better shower containment.**
- **Smaller (radius) ECAL, i.e. smaller (radius) solenoid, which leads to a big saving.**

Heat production more evenly spread over surface of sensor.

Relative to conventional silicon diodes, MAPS are roughly half the price: \$ 4/cm² compared to \$ 10/cm².

Indications of improved energy resolution for EM showers of 20% for single electrons.

MAPS - improvements

Linearity

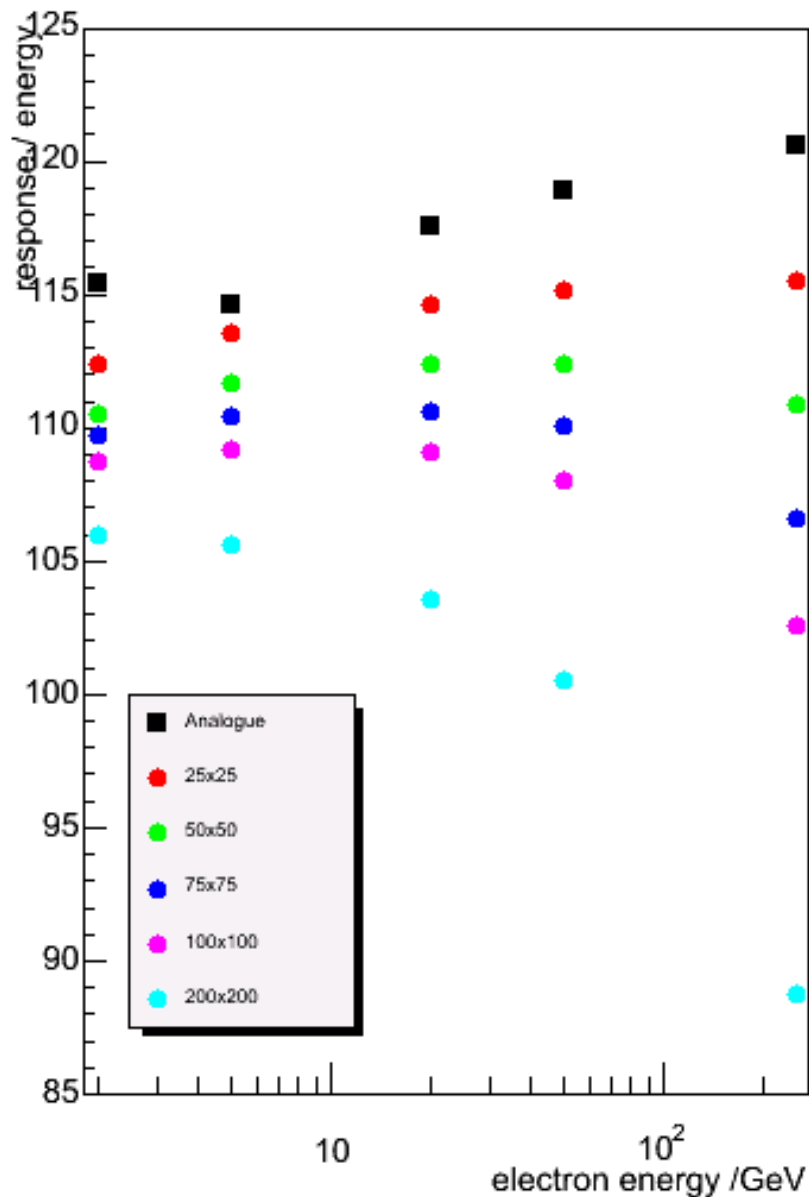

Resolution

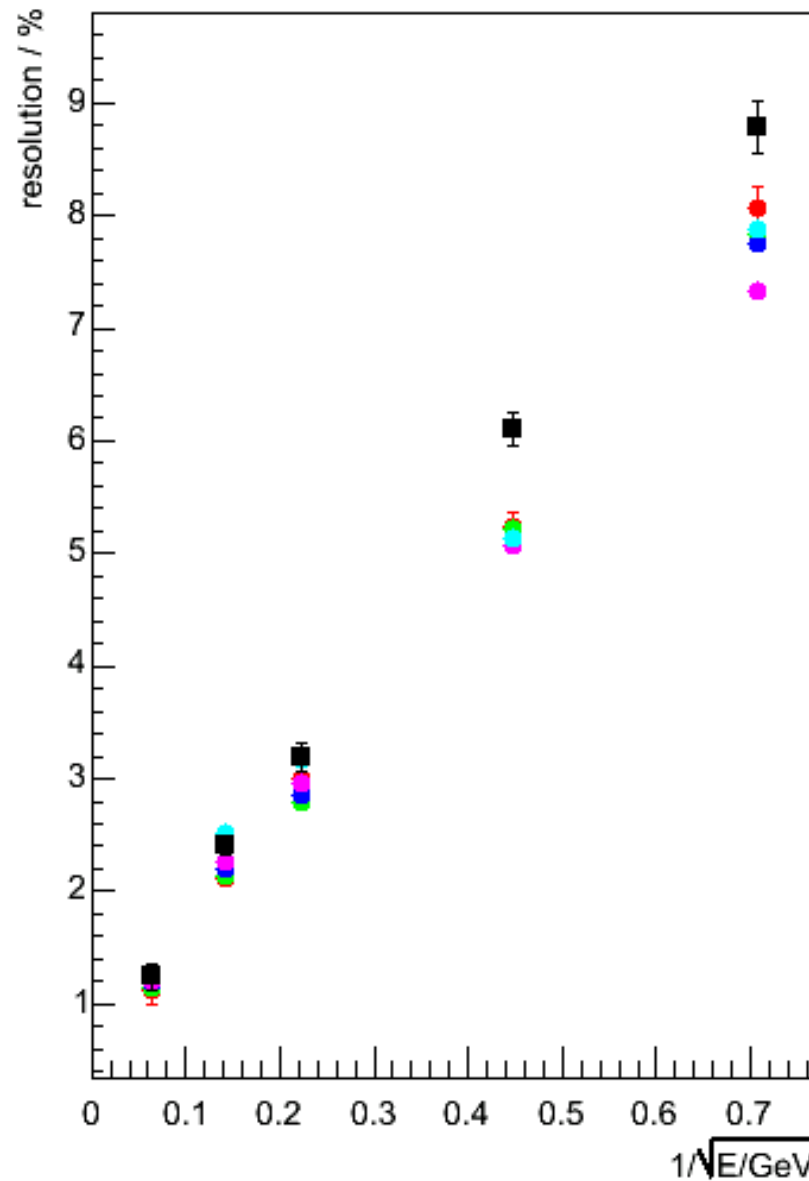

MAPS - R&D programme

Signal/noise for binary readout. No pulse height information; physical particles and noise harder to distinguish. Reset or not.

Crosstalk. Inefficient charge collection in epitaxial layer leads to charge being collected by neighbouring pixels. Balance layer thickness and signal size.

Uniformity and stability. A threshold cannot be set per pixel, so uniformity needed per sensor. And stability needed with temperature changes.

Power dissipation has so be the same (or less) as for the diode-pad option.

Program of sensor fabrication wit bench tests before verification in a beam test using current ECAL pre-prototype set up.

Mechanical/Thermal issues

Getting cooling into compact area - main source VFE chip.

Thermal modelling and comparison with measurements on slab mock-ups; feedback to VFE and mechanical design team.

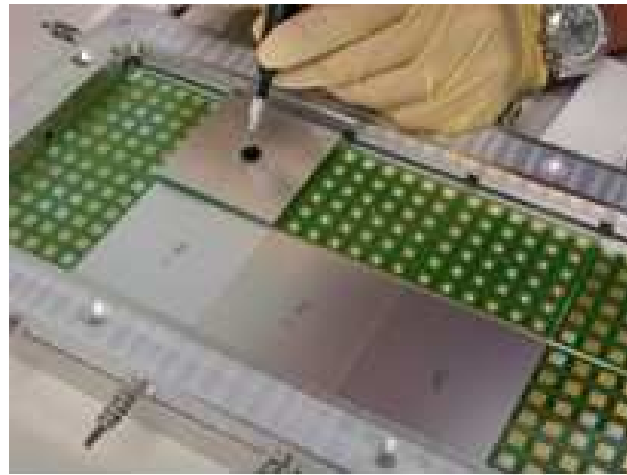
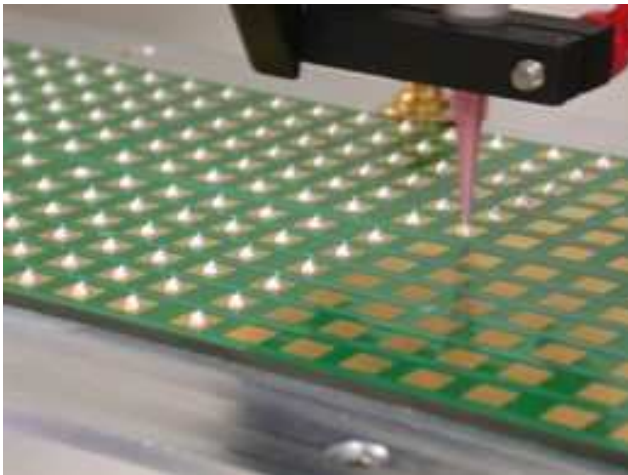

Ageing of glues through thermal cycling, diffusion into wafer.

Automation of assembly building prototype and test of accuracy.

Summary

The realisation of a high-energy linear collider has been given a boost with the accelerator technology decision of 2004.

Detector (and accelerator) R&D can now become more focused. Baseline design for a calorimeter.

Concept for a “tracking” calorimeter is being verified; test-beam running underway.

UK groups (hoping) to embark on a significant programme of R&D.

Additional slides

Pion tracked at 5 GeV

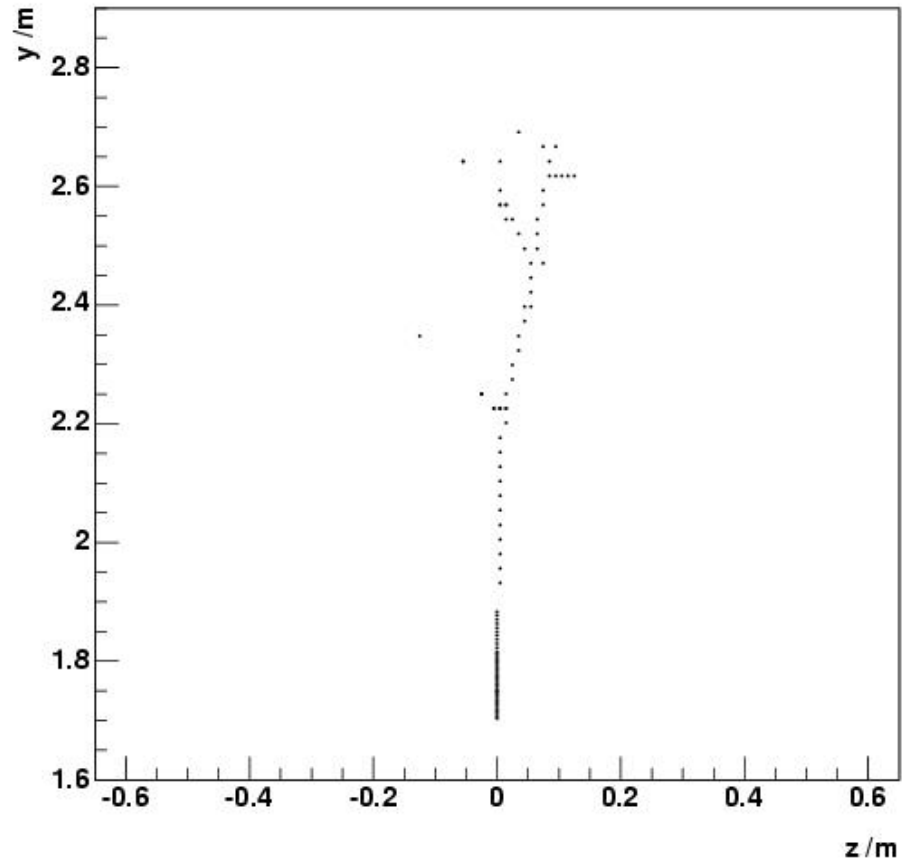

MAPS 2-particle separation

