

DO NOT SCALE FROM THIS PRINT

DESIGNED & DIMENSIONED IN MILLIMETERS [INCHES]

SS4-XX-X.XX-X-D-X-XX-TR

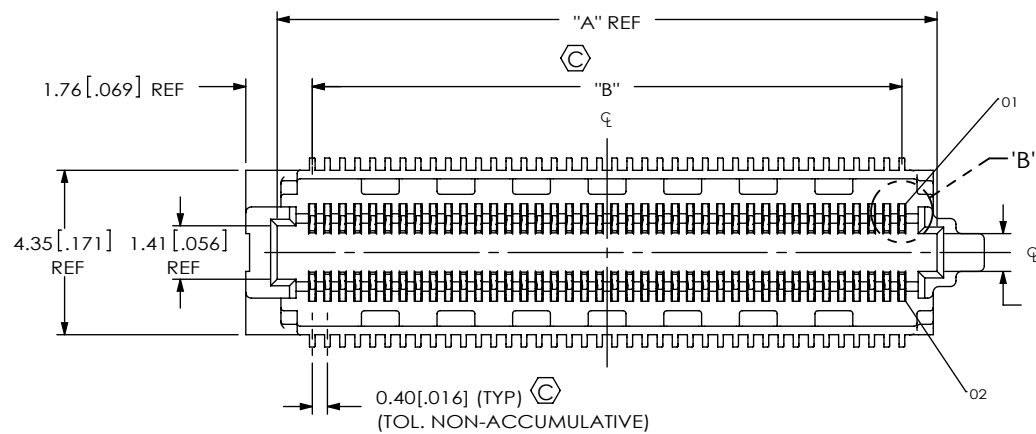

No OF POSITIONS
-10, -15, -20, -30, -40, -50 (PER ROW)

LEAD STYLE
-3.00: SEE FIG 1 (USE C-229-3.00-X)
-3.50: SEE FIG 2, SHT 2 (USE C-229-3.50-X)

PLATING
-L: 10µm SELECTIVE GOLD IN CONTACT AREA, MATTE TIN ON TAIL (USE C-229-X.XX-X)

ROW SPECIFICATION
-D: DOUBLE

PACKAGING
-TR: TAPE AND REEL PACKAGING (SEE NOTE 4)

PLACEMENT PAD
-K: KAPTON PAD (USE K-500-300) (SEE FIG 4 & 5, SHT 3)
**-PA: PICK & PLACE WITH ALIGNMENT PINS (SEE FIG 6, SHT 4) (NOT AVAILABLE IN -15 POS)

OPTIONS
*, **-L: LATCHING (USE WT-40-X.XX-T) (SEE FIG 3, SHT 2 AND NOTE 3) (LEAVE BLANK FOR NO OPTION)

* = TOOLED ONLY FOR THE -3.00 LEAD STYLE
** = AVAILABLE FOR EXISTING CUSTOMERS ONLY

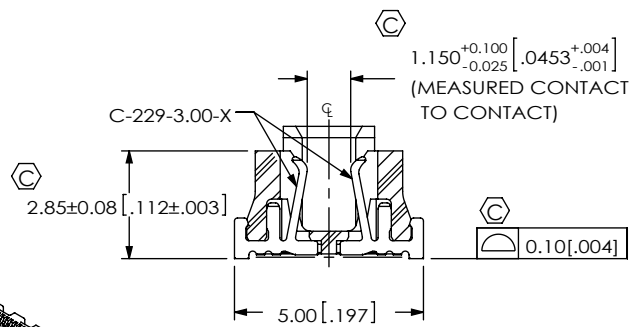
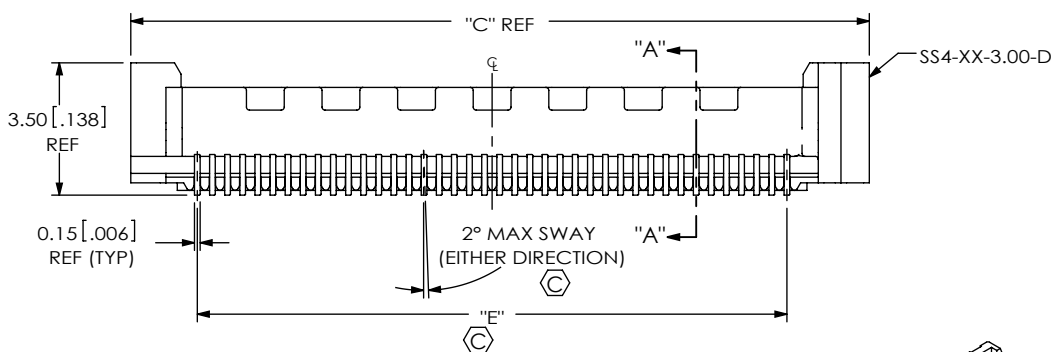

SECTION "A"- "A"
SCALE 5 : 1

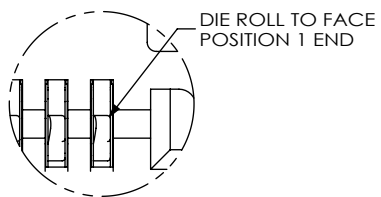

DETAIL 'B'
SCALE 15 : 1

POS	"A"	"B"	"C"	"E"
-10	5.46 [0.215]	3.60 [0.142]	7.54 [0.297]	3.60 [0.142]
-15	7.46 [0.294]	5.60 [0.220]	9.54 [0.376]	5.60 [0.220]
-20	9.46 [0.372]	7.60 [0.299]	11.54 [0.454]	7.60 [0.299]
-30	13.46 [0.530]	11.60 [0.457]	15.54 [0.612]	11.60 [0.457]
-40	17.46 [0.687]	15.60 [0.614]	19.54 [0.769]	15.60 [0.614]
-50	21.46 [0.845]	19.60 [0.772]	23.54 [0.927]	19.60 [0.772]

FIG 1
SS4-40-3.00-L-D SHOWN

SS4 LEAD STYLE	TABLE 2 REF STACK HEIGHT		
	ST4 LEAD STYLE		
-1.00	-1.00	-1.50	-2.50
-3.00	4.0[.16]	4.5[.18]	5.5[.22]
-3.50	4.5[.18]	5.0[.20]	6.0[.24]

NOTES:

- ⊕ REPRESENTS A CRITICAL DIMENSION.
- MINIMUM PUSHOUT FORCE: 2.22N [.5 LB].
- L: LATCHING OPTION NOT INTENDED FOR ALIGNMENT TO PCB. AUTOMATED PLACEMENT IS RECOMMENDED.
- FOR QUANTITIES UP TO 49 PIECES, NO LEADER, TRAILER, OR REEL WILL BE SUPPLIED. FOR QUANTITIES OF 50-124 PIECES, NO LEADER OR TRAILER WILL BE SUPPLIED.

UNLESS OTHERWISE SPECIFIED, DIMENSIONS ARE IN MILLIMETERS. TOLERANCES ARE:
DECIMALS ANGLES
.X: ±0.3 [0.1] 2°
.XX: ±0.13 [0.05]
.XXX: ±0.051 [0.020]

PROPRIETARY NOTE
THIS DOCUMENT CONTAINS INFORMATION CONFIDENTIAL AND PROPRIETARY TO SAMTEC, INC. AND SHALL NOT BE REPRODUCED OR TRANSFERRED TO OTHER DOCUMENTS OR DISCLOSED TO OTHERS OR USED FOR ANY PURPOSE OTHER THAN THAT WHICH IT WAS OBTAINED WITHOUT THE EXPRESSED WRITTEN CONSENT OF SAMTEC, INC.

MATERIAL:
INSULATOR: LCP, UL 94 V0, COLOR: BLACK
CONTACT: PHOS BRONZE
LATCH: PHOS BRONZE

DO NOT SCALE DRAWING SHEET SCALE: 2:1



520 PARK EAST BLVD, NEW ALBANY, IN 47150
PHONE: 812-944-6733 FAX: 812-948-5047
e-Mail: info@SAMTEC.com code: 55322

DESCRIPTION:
0.4mm [0.016] SOCKET STRIP ASSEMBLY

DWG. NO.
SS4-XX-X.XX-X-D-X-XX-TR

BY: CLAY W 4/19/2007 SHEET 1 OF 4

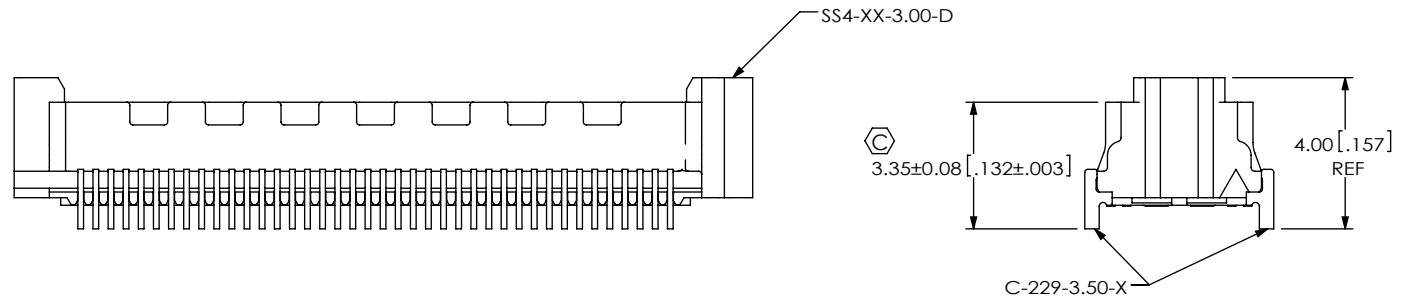

FIG 2
-3.50 BODY HEIGHT
SS4-40-3.50-X-D SHOWN
(DIFFERENT AS SHOWN, OTHERWISE SAME AS FIG 1)

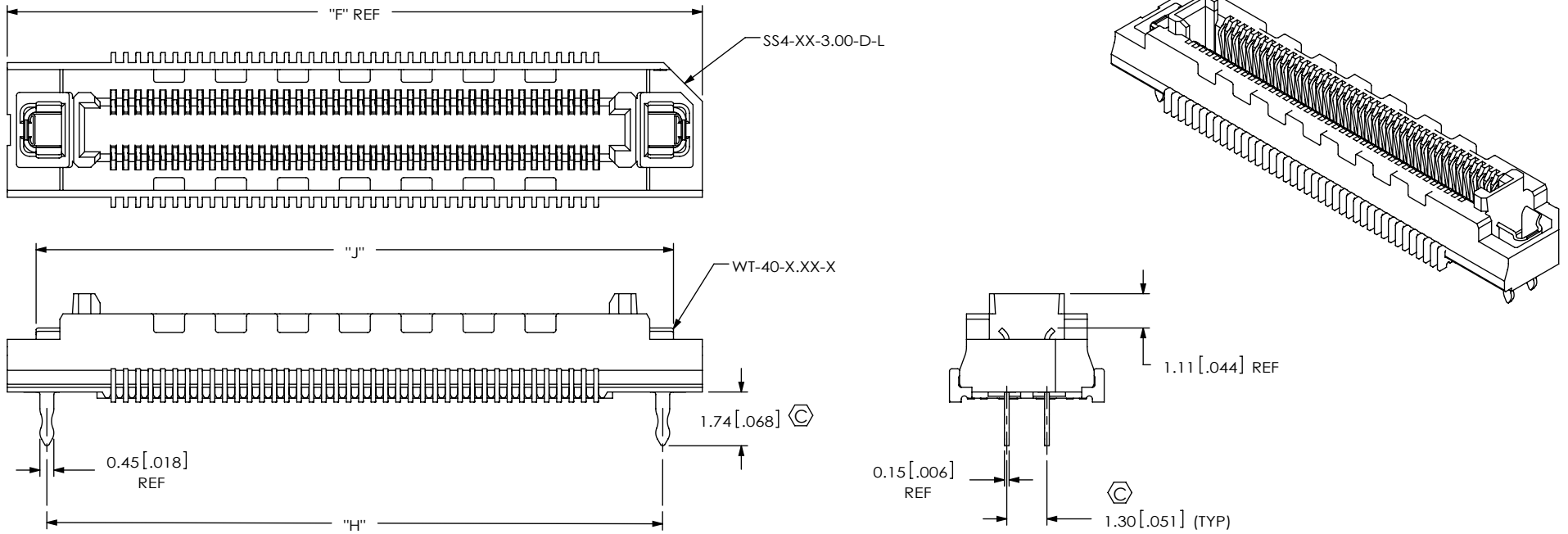

FIG 3
* **-L: LATCHING OPTION
SS4-40-3.00-X-D-L SHOWN
(DIFFERENT AS SHOWN, OTHERWISE SAME AS FIG 1)
* = TOOLED ONLY FOR THE -3.00 LEAD STYLE
** = AVAILABLE FOR EXISTING CUSTOMERS ONLY

POS	"F"	"H"	"J"
-10	10.46 [0.412]	7.90 [0.311]	8.60 [0.339]
-15	12.46 [0.491]	9.90 [0.390]	10.60 [0.417]
-20	14.46 [0.569]	11.90 [0.469]	12.60 [0.496]
-30	18.46 [0.727]	15.90 [0.626]	16.60 [0.654]
-40	22.46 [0.884]	19.90 [0.783]	20.60 [0.811]
-50	26.46 [1.042]	23.90 [0.941]	24.60 [0.969]

LEAD STYLE	LATCH
-3.00	W-40-3.00-T
-3.50	*WT-40-3.50-T

(* = NOT TOOLED)

PROPRIETARY NOTE
THIS DOCUMENT CONTAINS INFORMATION CONFIDENTIAL AND PROPRIETARY TO SAMTEC, INC. AND SHALL NOT BE REPRODUCED OR TRANSFERRED TO OTHER DOCUMENTS OR DISCLOSED TO OTHERS OR USED FOR ANY PURPOSE OTHER THAN THAT WHICH IT WAS OBTAINED WITHOUT THE EXPRESSED WRITTEN CONSENT OF SAMTEC, INC.

DO NOT SCALE DRAWING

SHEET SCALE: 5:1



520 PARK EAST BLVD, NEW ALBANY, IN 47150
PHONE: 812-944-6733 FAX: 812-948-5047
e-Mail: info@SAMTEC.com code: 55322

DESCRIPTION:
0.4mm [.016] SOCKET STRIP ASSEMBLY
DWG. NO.
SS4-XX-X.XX-X-D-X-XX-TR

BY: CLAY W 4/19/2007 SHEET 2 OF 4

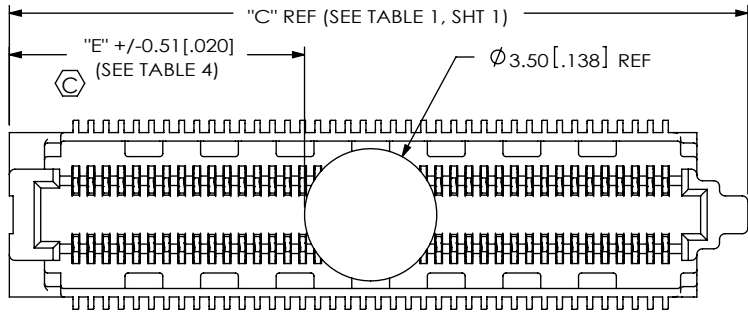

FIG 4
 -K: KAPTON OPTION
 SS4-40-3.00-X-D-K SHOWN
 (USE K-500-300)
 (DIFFERENT AS SHOWN, OTHERWISE SAME AS FIG 1)

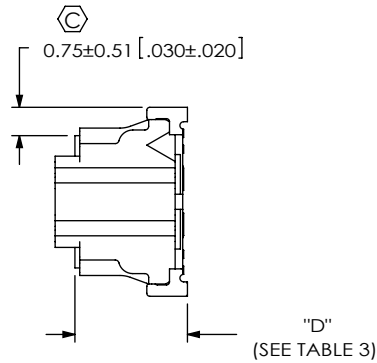

TABLE 3	
LEAD STYLE	"D"
-3.00	2.98 [.117]
-3.50	3.48 [.137]

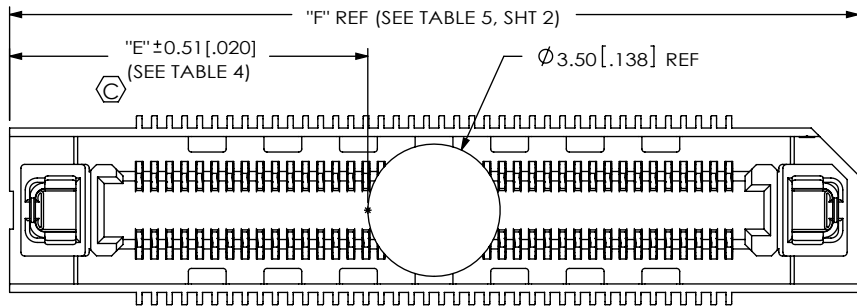

FIG 5
 -K: KAPTON OPTION(W/ -L OPTION)
 SS4-40-3.00-X-D-L-K SHOWN
 (USE K-500-300)
 (DIFFERENT AS SHOWN, OTHERWISE SAME AS FIG 1)

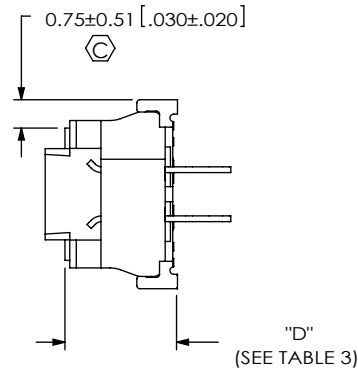

TABLE 4		
POS	"E" W/O -L OPTION	"E" W/ -L OPTION
-10	1.48 [0.058]	3.48 [0.137]
-15	2.48 [0.098]	4.48 [0.176]
-20	3.48 [0.137]	5.48 [0.216]
-30	5.48 [0.216]	7.48 [0.294]
-40	7.48 [0.294]	9.48 [0.373]
-50	9.48 [0.373]	11.48 [0.452]

PROPRIETARY NOTE

THIS DOCUMENT CONTAINS INFORMATION CONFIDENTIAL AND PROPRIETARY TO SAMTEC, INC. AND SHALL NOT BE REPRODUCED OR TRANSFERRED TO OTHER DOCUMENTS OR DISCLOSED TO OTHERS OR USED FOR ANY PURPOSE OTHER THAN THAT WHICH IT WAS OBTAINED WITHOUT THE EXPRESSED WRITTEN CONSENT OF SAMTEC, INC.

DO NOT SCALE DRAWING

SHEET SCALE: 5:1

samtec

520 PARK EAST BLVD, NEW ALBANY, IN 47150
 PHONE: 812-944-6733 FAX: 812-948-5047
 e-Mail: info@SAMTEC.com code: 55322

DESCRIPTION:
 0.4mm[.016] SOCKET STRIP ASSEMBLY

DWG. NO.
SS4-XX-X.XX-X-D-X-XX-TR

BY: CLAY W 4/19/2007 SHEET 3 OF 4

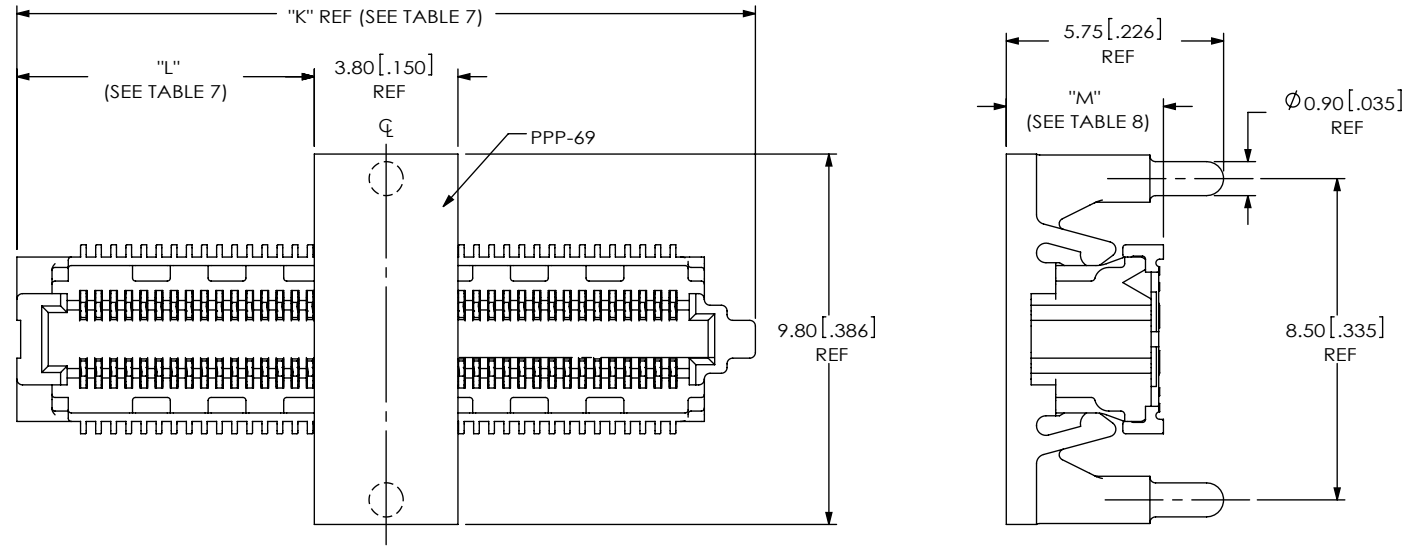

FIG 6
****_PA: PICK & PLACE PAD WITH ALIGNMENT PINS**
 SS4-40-3.00-X-D-PA SHOWN
 (DIFFERENT AS SHOWN, OTHERWISE SAME AS FIG 1)
 (NOT AVAILABLE IN -15 POS)
 ** = AVAILABLE FOR EXISTING CUSTOMERS ONLY

LEAD STYLE	"M"
-3.00	4.16 [.164]
-3.50	4.66 [.183]

POS	"K"	"K"	"L"	"L"
	W/O -L OPTION	W/ -L OPTION	W/O -L OPTION	W/ -L OPTION
-10	7.54 [0.297]	10.46 [0.412]	1.87 [0.074]	3.33 [0.131]
-20	11.54 [0.454]	14.46 [0.569]	3.87 [0.152]	5.33 [0.210]
-30	15.54 [0.612]	18.46 [0.727]	5.87 [0.231]	7.33 [0.289]
-40	19.54 [0.769]	22.46 [0.884]	7.87 [0.310]	9.33 [0.367]
-50	23.54 [0.927]	26.46 [1.042]	9.87 [0.389]	11.33 [0.446]

PROPRIETARY NOTE
 THIS DOCUMENT CONTAINS INFORMATION CONFIDENTIAL AND PROPRIETARY TO SAMTEC, INC. AND SHALL NOT BE REPRODUCED OR TRANSFERRED TO OTHER DOCUMENTS OR DISCLOSED TO OTHERS OR USED FOR ANY PURPOSE OTHER THAN THAT WHICH IT WAS OBTAINED WITHOUT THE EXPRESSED WRITTEN CONSENT OF SAMTEC, INC.

DO NOT SCALE DRAWING

SHEET SCALE: 5:1

samtec

520 PARK EAST BLVD, NEW ALBANY, IN 47150
 PHONE: 812-944-6733 FAX: 812-948-5047
 e-Mail: info@SAMTEC.com code: 55322

DESCRIPTION:
 0.4mm [.016] SOCKET STRIP ASSEMBLY

DWG. NO.
 SS4-XX-X.XX-X-D-X-XX-TR

BY: CLAY W 4/19/2007 SHEET 4 OF 4