

# UK CMS Upgrade Oversight Committee

---

25 November 2014

University of Bristol  
Brunel University London  
Imperial College London  
Rutherford Appleton Laboratory

Geoff Hall

# Overview

- Snapshots of LHC & CMS status
  - a few slides from LHCC reports 19 November –
  - CMS also on schedule for restart
- Summary of UK upgrade project
  - Recent WP progress
- Finances
  
- Follow with more detailed report of Trigger upgrade progress

# Conclusions

- Steady progress but little contingency left:
  - Cool-down has gone well
  - CSCM\*: additional overhead, but invaluable, 7/8 complete – excellent results
  - Important commissioning/debugging of other systems
  - Powering tests thus far have gone well
- Most of the preparation work will be completed in 2014, opening the way to intensive powering test campaign in 2015
  - Experience with training in S12 will be the benchmark

\* Copper Stabiliser Current Measurement

# Cool-down - status

Sector 12	1.9 K	CSCM OK
Sector 23	5 K	CSCM OK
Sector 34	26 K	
Sector 45	20 K	CSCM OK
Sector 56	1.9 K	CSCM OK
Sector 67	1.9 K	CSCM OK
Sector 78	5 K	CSCM OK
Sector 81	1.9 K	CSCM OK

**Represents a major and successful effort by  
the cryogenics group**

# The first (re)training quench S67

- After the successful execution of the previous steps, the first ramp to nominal current was executed, leading to the first training quench at a current of 9779 A (corresponding to a bit less than 5.8 TeV)

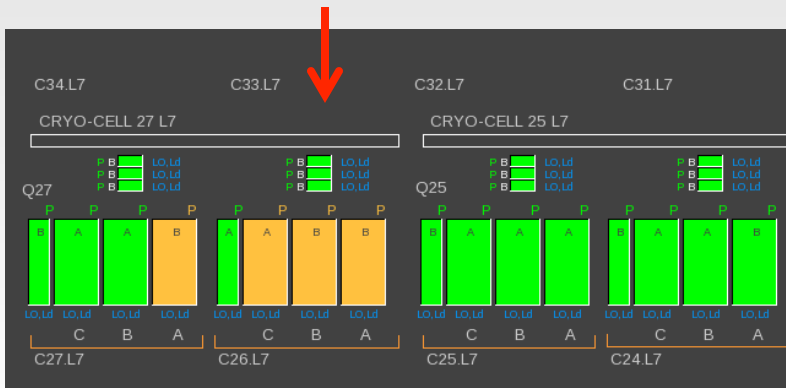

- Secondary quenches were detected
  - A26L7            4248 A
  - C26L7            4235 A
  - A27L7            381 A

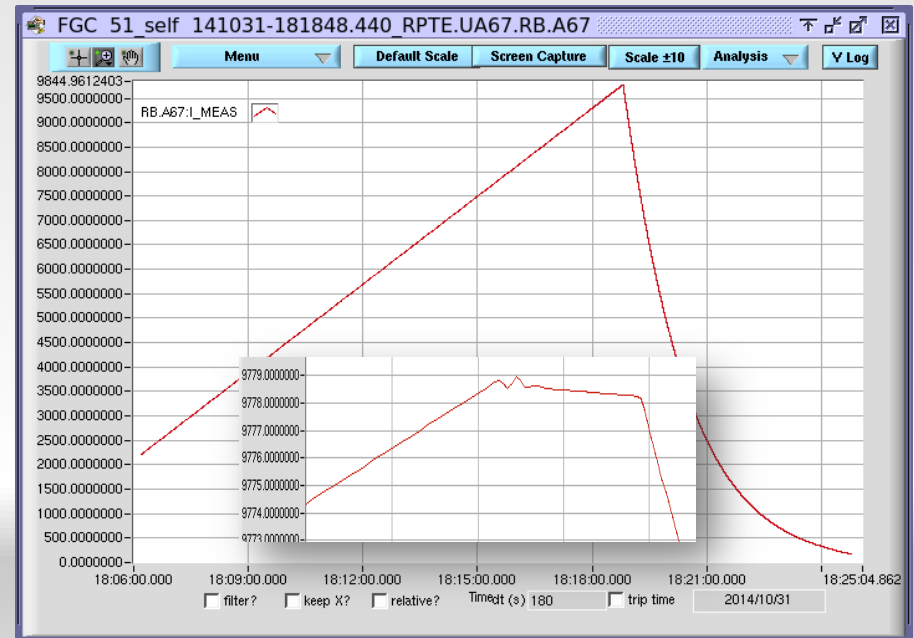

## SM18 data for the first quenching magnet:

3285	Quench 1	Quench 2
I (A)	8391	12782
B (T)	5.93	8.96
E (TeV)	5.0	7.5

# 2015 LHC schedule

◆ Main phases:

1. Low intensity commissioning (2 months)
2. First physics with a few isolated bunches, LHCf run
3. First scrubbing run (50 ns)
4. 50 ns operation (up to 1380 bunches/beam)
  - 21 days*
5. 25 ns scrubbing run
6. 25 ns operation + special runs
  - ~90 days*
  - Potentially with two  $\beta^*$  values*
7. Ion run

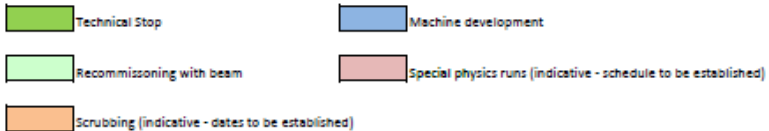
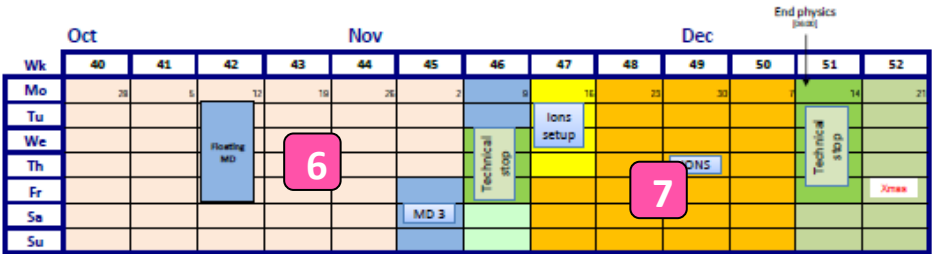
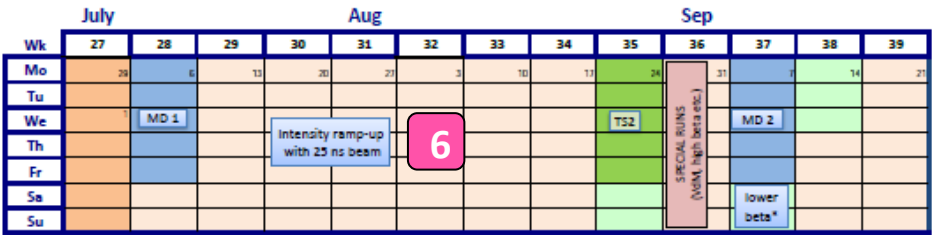
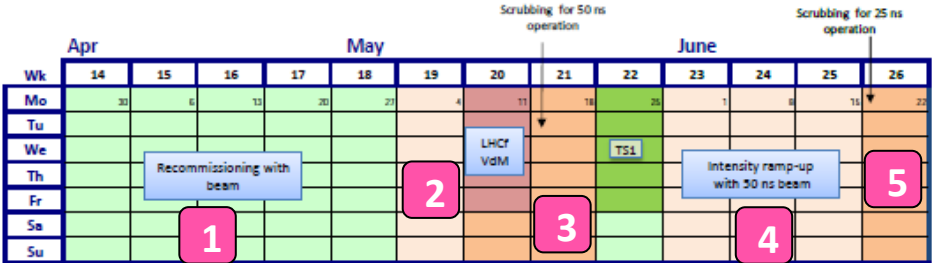
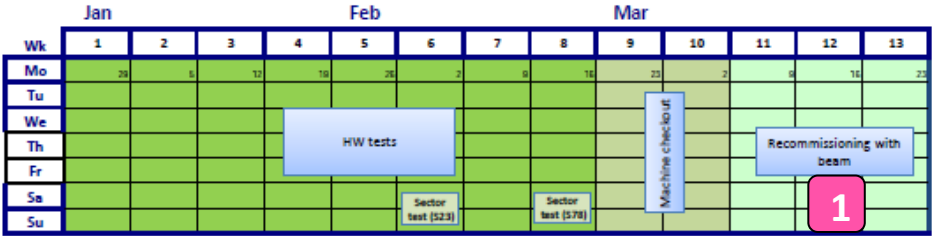

# Expectation for 2015

- Assuming ~35% availability.
  - Intensity ramp up with 25 ns = 7 weeks = length first period.
- Uncertainties:
  - Length of operation period ( $\beta^*$  step – when).
  - Value of  $\beta^*$  step.
  - Beam parameters...

Period	$N_{\text{bunch}}$ [ $10^{11}$ ]	$\epsilon^*$ [mm]	k	$\beta^*$ [cm]	L [ $\text{cm}^{-2}\text{s}^{-1}$ ]	$\langle\mu\rangle$	Days(*)	$\int L$ [fb $^{-1}$ ]
50 ns	1.2	2.2	$\approx 1370$	80	$5.3 \times 10^{33}$	30	21	$\approx 1$
25 ns / 1	1.2	2.5	$\approx 2500$	80	$8.1 \times 10^{33}$	26	44	$\approx 4$
25 ns / 2	1.2	2.5	$\approx 2500$	40	$14.7 \times 10^{33}$	45	46	$\approx 13$

(\*) no. of days of operation on the current schedule

Statement by F. Bordry :

*2015 will be a re-commissioning year to prepare physics production in 2016*

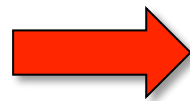

Goal for 2015  
(Bordry dixit)

$$\int L \approx 10 \text{fb}^{-1}$$

# Tracker detector

Getting cold! Mitigate long term radiation damages (being operated at -15C)

New bulkhead panels with heating elements



Excellent performance of

- Seal ✓
- Dry gas system ✓
- Heater elements outside ✓
- Dew point sensors ✓



Final test with CMS closed and full B-field successful

# Magnet test

- Goals: Use repair time for barrel pixel to anticipate later activities, clear endgame risk
- Go through detector closing procedure. CMS closed in  $\sim 1$  month, as expected
- Magnet ramp up without incidents. Stable at 3.8T for  $\sim 1.5$  days.

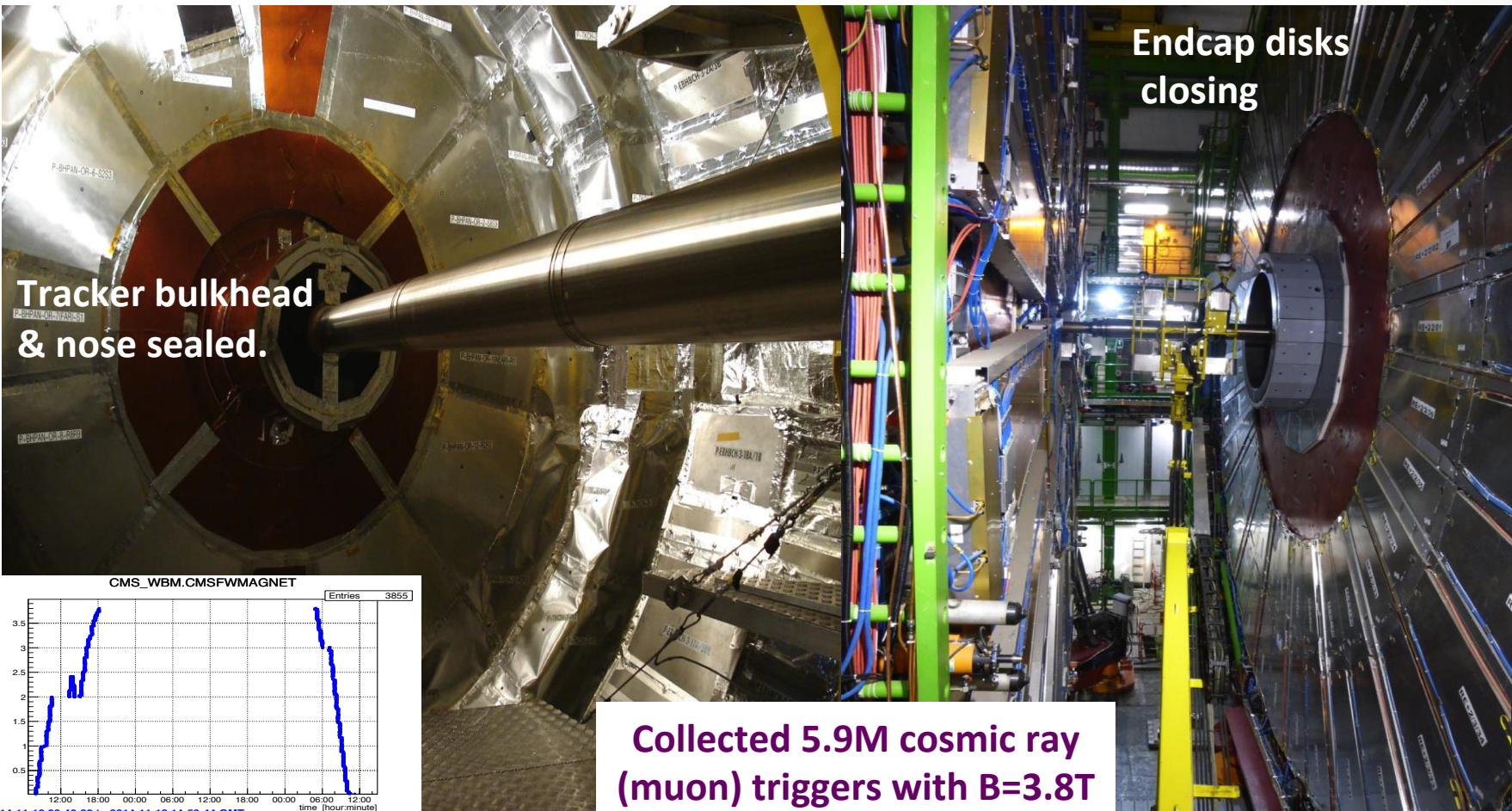

Tracker bulkhead & nose sealed.

Endcap disks closing

Collected 5.9M cosmic ray (muon) triggers with  $B=3.8T$

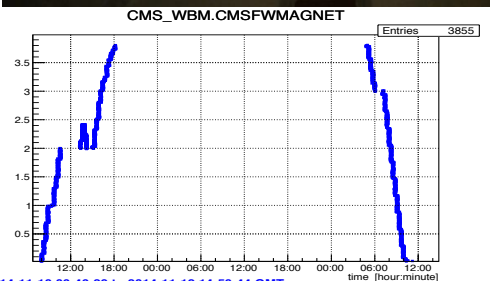

# First results from Magnet test

- Stable running with all subsystems
- Strips: In the run at -15C
- ECAL: Recorded laser calibration data at 3.8 T
- HCAL:
  - Gain of new HF PMTs does not change due to fringe fields at 3.8T
  - Noise rate of HBHE HPDs at 3.8T similar to Run1
- Muon Systems:
  - Good trigger behaviour (primary source for cosmic rays)
  - Successful inclusion of new/upgraded CSC and new endcap RPC muon chambers

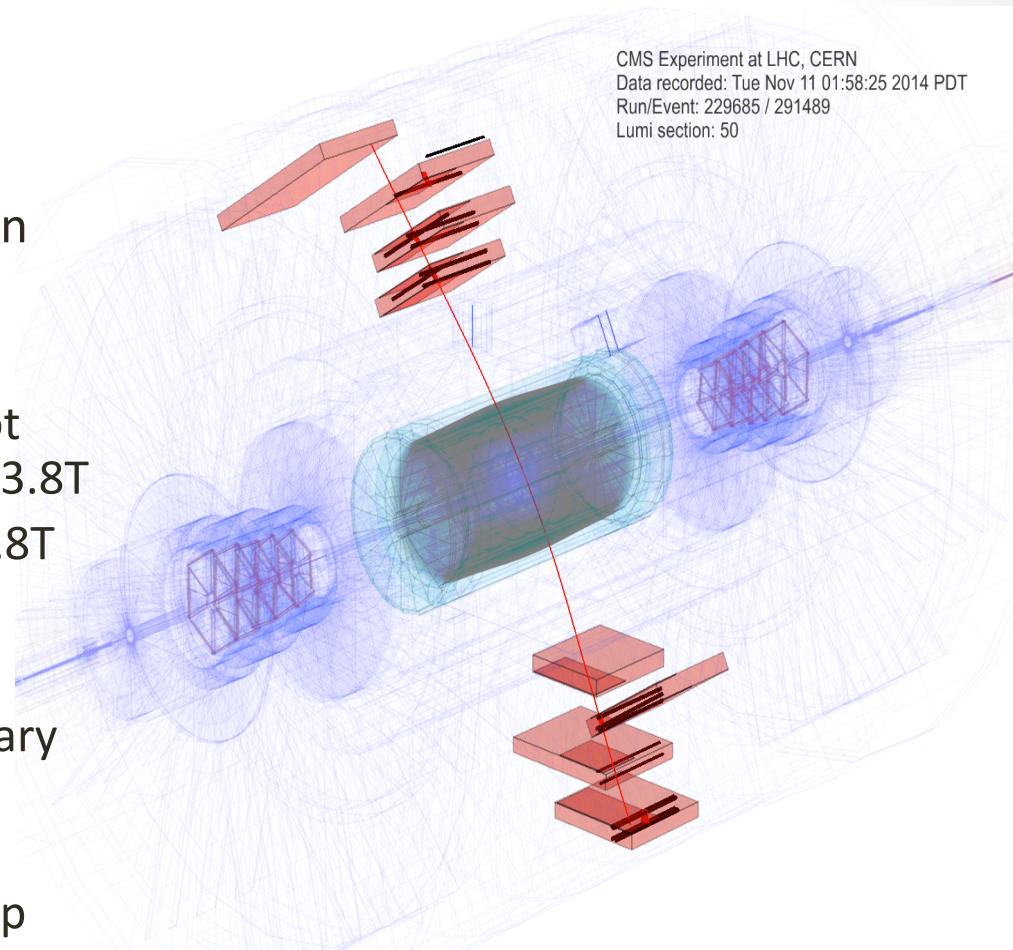

# Pixel detector

- **BPIX half-shell fully repaired and back to CERN**
- Reminder: **failure was localized in one quadrant only**– all others fine
  - Failure: shorts between wire-bonding pads on the high density interconnect
  - Isolated failure during a test with power and most probable high local humidity
- 40 new modules
- 19 repaired modules
- **This half-shell works now 100%!**
- Connection to supply tube done ✓
- Initial checkout done ✓
- Ready for installation by end of November

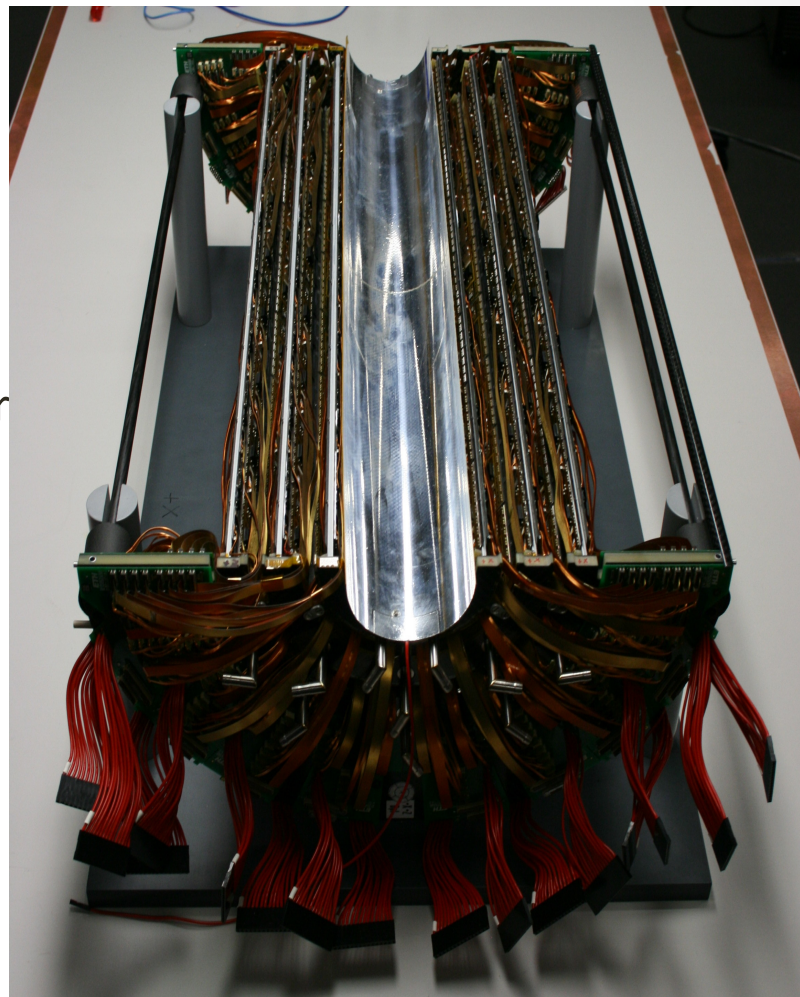

# L1 Trigger Upgrade: Calorimeter

Current L1 Trigger System

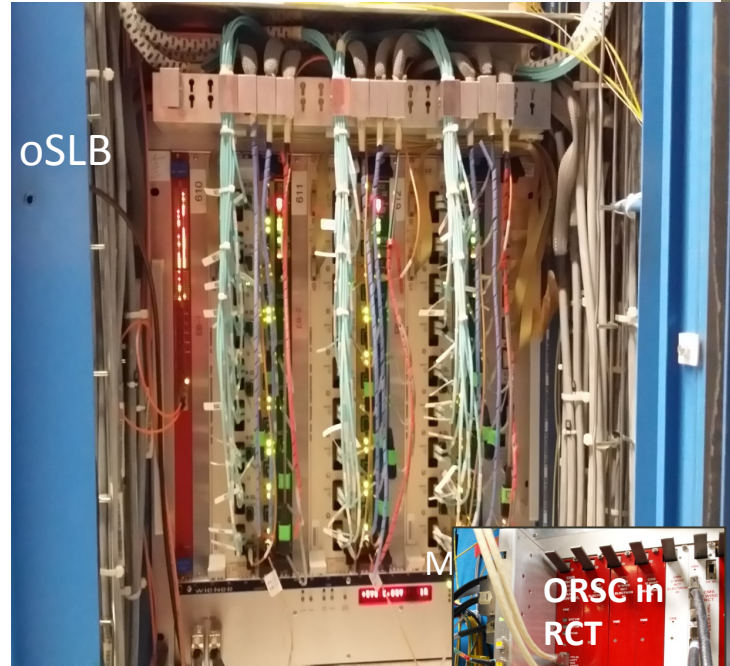
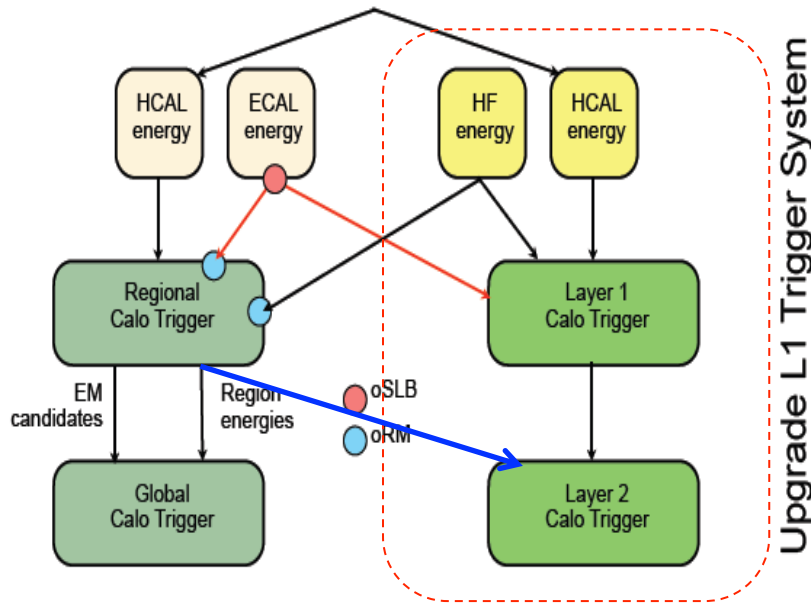

- Replacement of copper cable connections with **optical connections**.
  - **Splitting** from ECAL to Regional Calo Trigger and Layer 1 ✓
  - **Splitting** from Regional Calo Trigger to Global Calorimeter Trigger and Layer 2 ✓
  - **Configurable** switching legacy/upgrade
- Started installation of the final calorimeter trigger for 2016

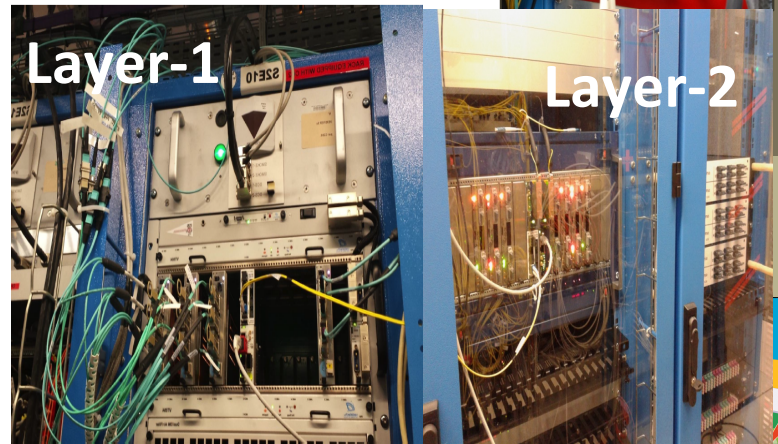

# Phase 2 upgrade planning

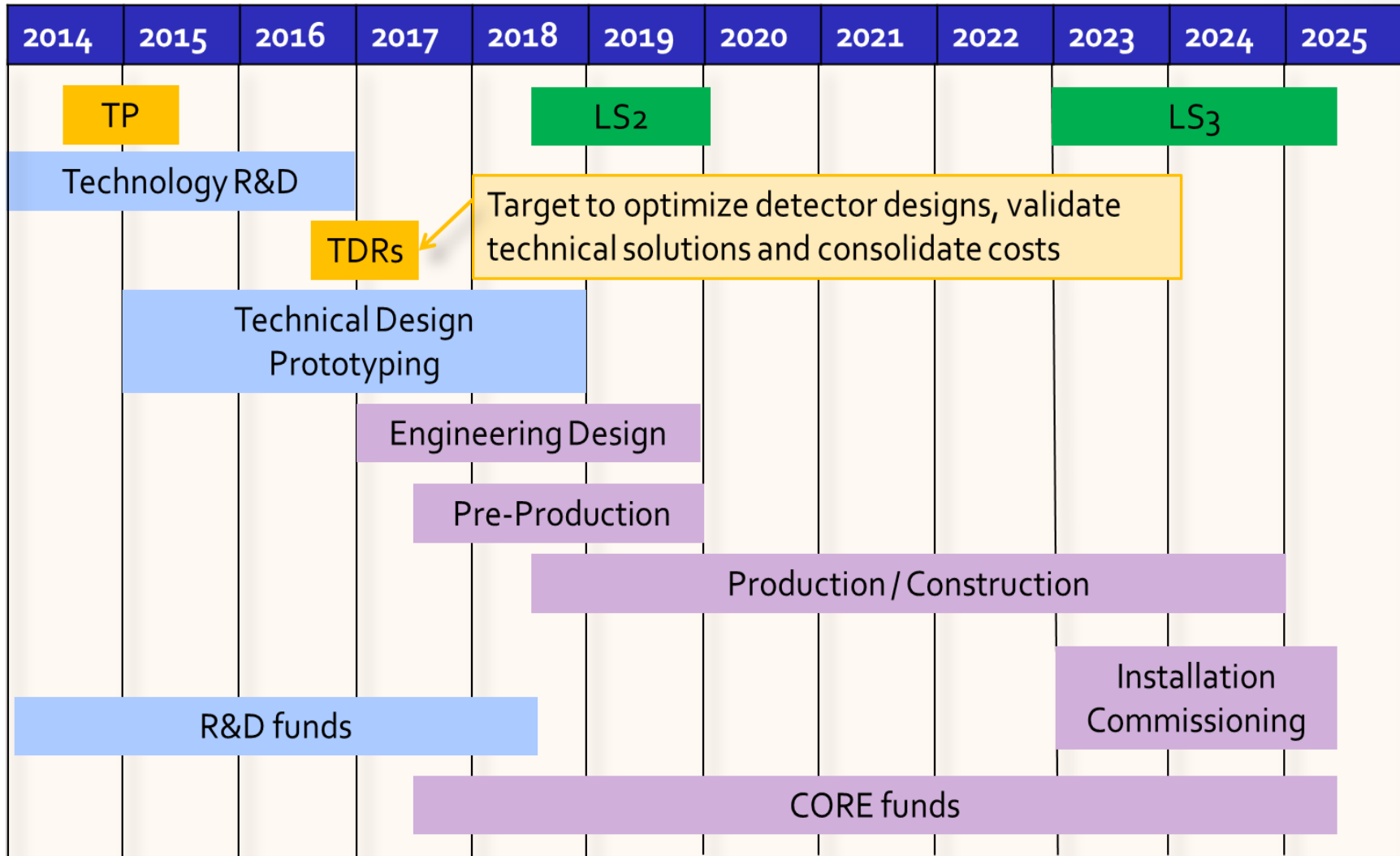

# UK R&D status

## Last 6 months

- WP2: SEU and radiation tests
  - continued steady progress in regular system discussions
  - expected CBC3 submission date defined & continued progress with design
  - CBC test setups being delivered
  - FC7 development largely complete, with successful production
- WP3: progress towards installation of TDR trigger
  - However, some concerns remain about US side of the project
  - UK work very productive and speed limited by external factors
    - additional report from D Newbold
- WP2 & WP3: progress on TMTT studies
- CMS TP delayed at suggestion of LHCC to March 2015
  - draft already seen by LHCC
    - decision on forward calorimetry Feb 2015

## WP2: Conclusions from x-ray irradiations

- Tests done at Diamond, including cooling to  $-15^{\circ}\text{C}$ 
  - M Raymond, D Braga
- CBC2 shows expected radiation insensitivity to  $\sim 40\text{ Mrad}$ 
  - Only observed effect was a **short term increase in current** which **recovers completely** even at  $-15^{\circ}\text{C}$  annealing after a few hours
  - Masked device allow to traced to pipeline memory cell leakage
    - unlikely to be a concern at LHC dose rates
    - but cell revision likely anyway

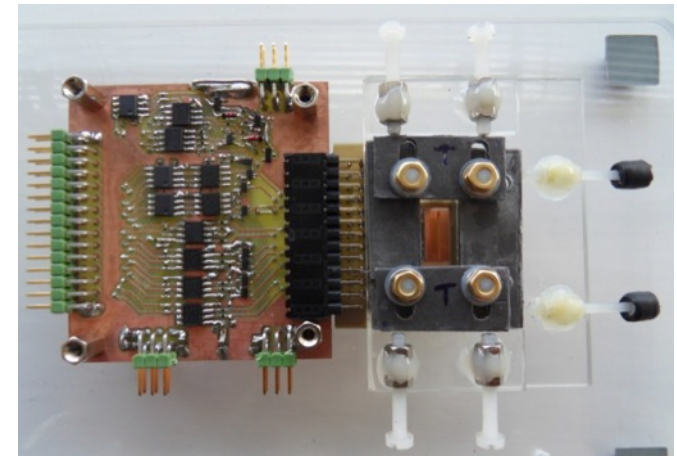
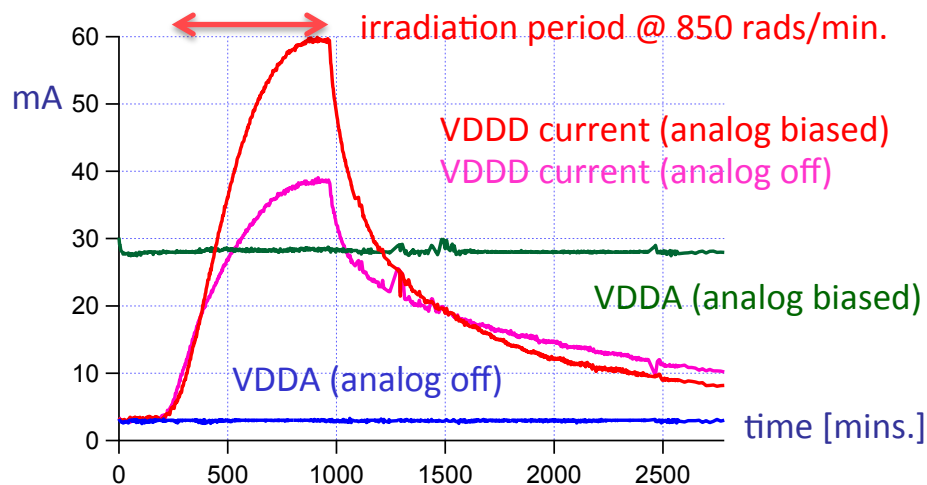

# SEU beam test

with collaborators at UC Louvain

- **Beam : Proton Cyclotron in Light Ion Irradiation Facility (LiF) at UC Louvain.**

Property	Value
Energy	Up to 62 MeV
Max Flux	$5 \times 10^8 \text{ p cm}^{-2}\text{s}^{-1}$
Homogeneity	10%
Spot size	8cm

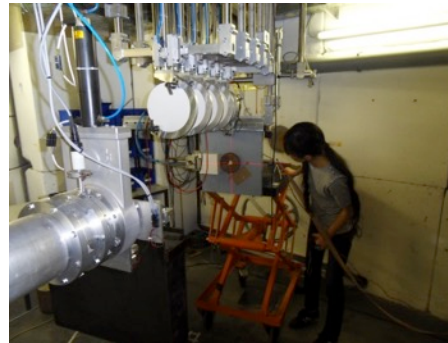

- **CBC2 module setup : 1 CBC2**

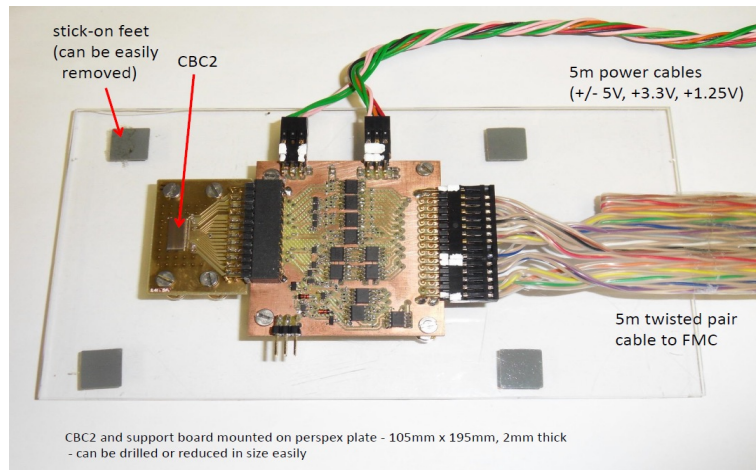

- **Error monitoring :  
I BE GLIB (Modified firmware)  
& CbcTest software**

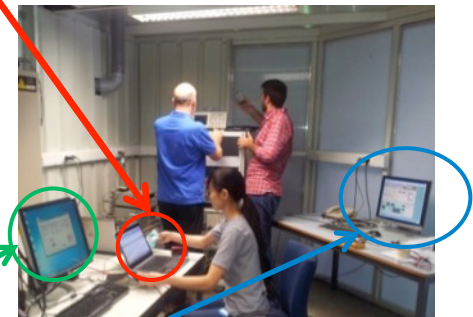
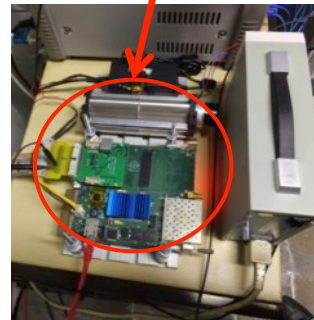

- **CBC current and beam monitoring system  
Thanks to Christophe and his colleagues**

# Summary

## Estimation of SEU per chip at HL-LHC with the assumption of $\Phi_{HL-LHC} = 1 \times 10^7 \text{ cm}^{-2}\text{s}^{-1}$

- SEU rate per chip in pipeline logic

$$r = [3.6 \pm 2.0] \times 10^{-2} \text{ hour}^{-1}$$

(If we consider the all 3 errors are due to the pipeline logic.)

- SEU rate per chip in pipeline cell

$$r < 7.1 \times 10^{-3} \text{ sec}^{-1} \text{ (CL=90\%)}$$

- Expected # of flipped bits in I2C register per chip without refresh.

$$N = [1.6 \pm 0.3] \times 10^{-1} \text{ SEU in an hour}$$

with the assumption that SEU happens on each cell independently.

$$N = [6.6 \pm 1.9] \times 10^{-1} \text{ SEU per hour}$$

with the assumption that SEU happens on multiple cells at the same time.

- **Pipeline logic and pipeline cells are performing very well, only a low “fast reset” rate will be required to recover upset chips**
- **I2C registers need to be mitigated more to be stable for a single run period.**
  - **we are planning to do this for CBC3**
- **Many more details in backup - note in preparation**

## CBC test stand

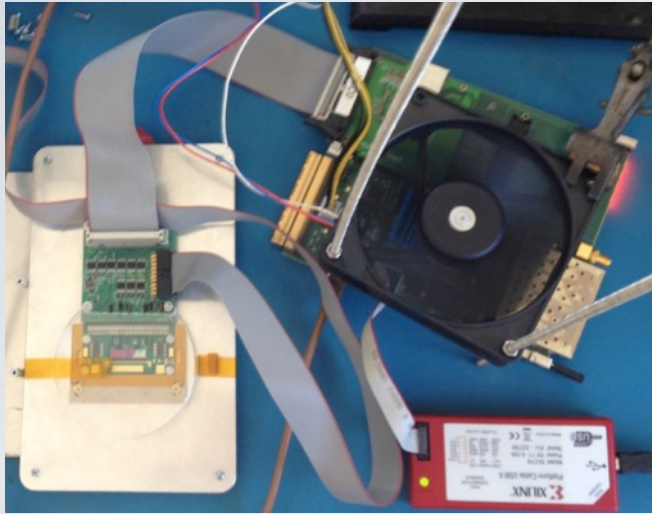

- Generic CBC2 system based on FPGA board
  - Currently using CERN GLIBv3
- Six “user” systems tested and shipped to institutes
  - Hybrid/module/systems testing
  - More being requested
- New version of software now in beta version
  - Based on middleware developed at CERN
  - Faster performance, lower overheads

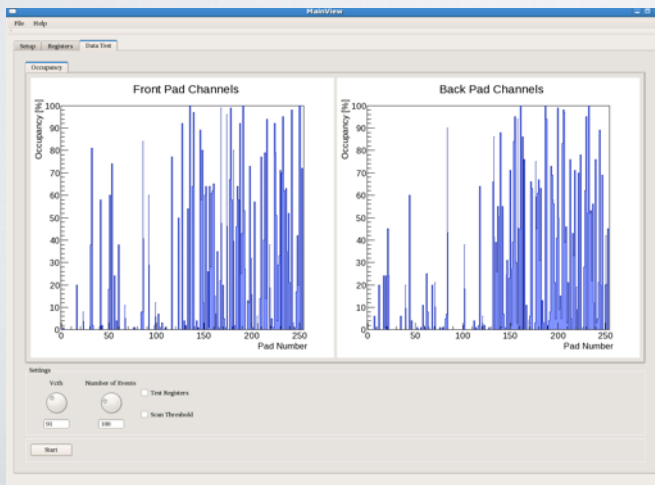

# CBC3 architecture

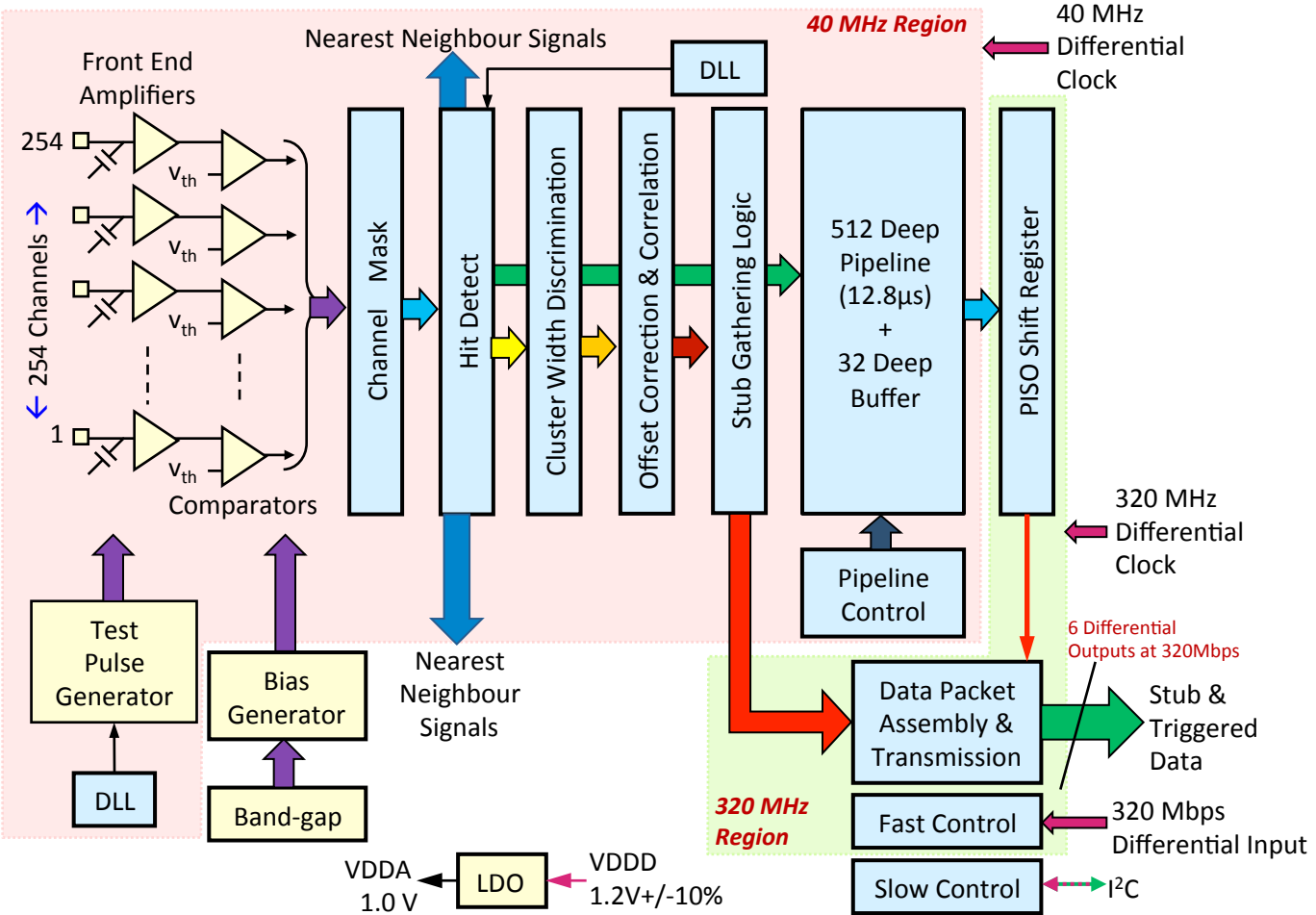

# CBC3 plan

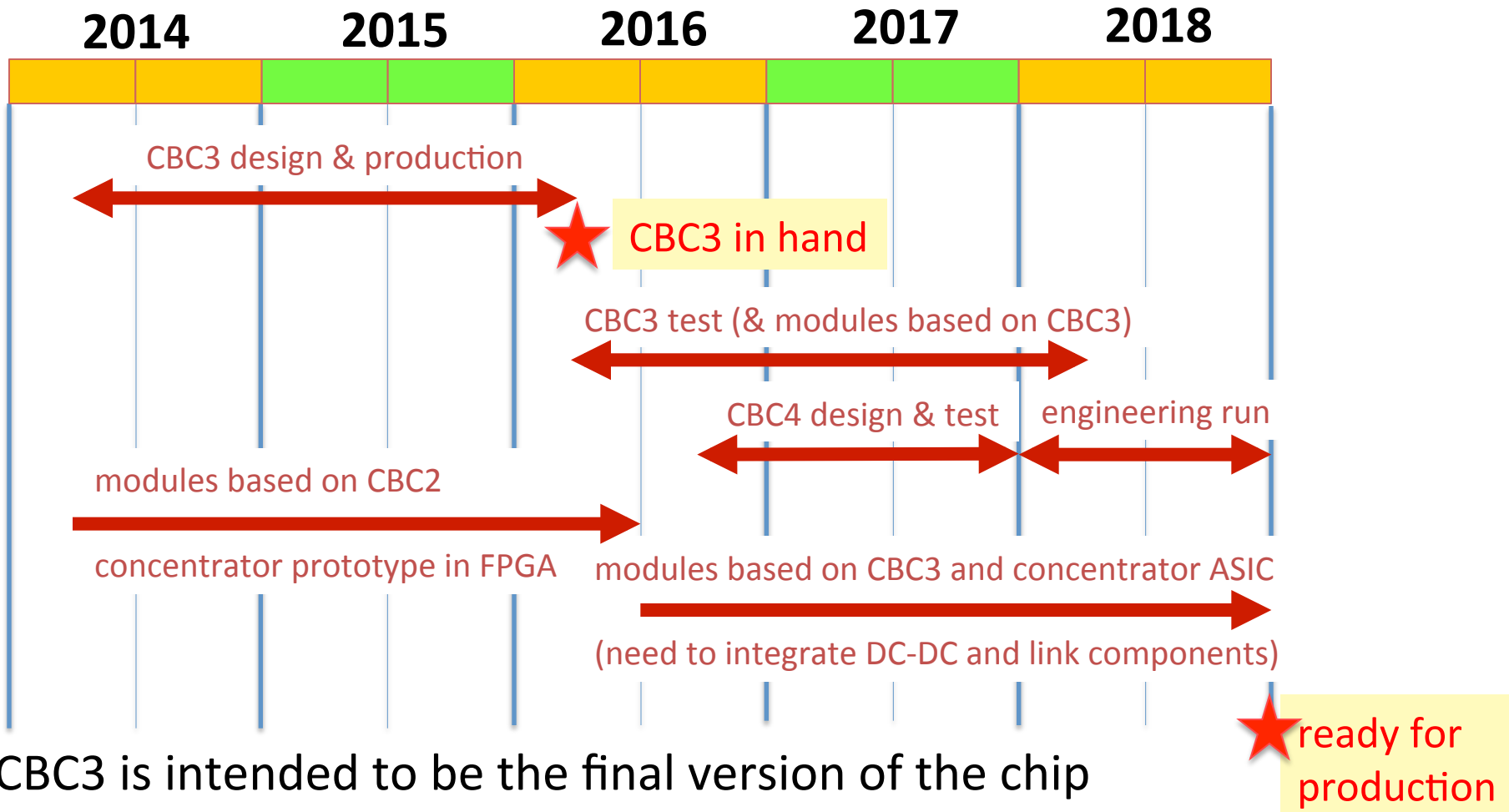

CBC3 is intended to be the final version of the chip  
*should be available ~ 1<sup>st</sup> half 2016*

CBC4 is an “insurance iteration” if something has to be fixed

principally designed with two CMS users in mind, plus use in upgrade R&D

- **Trigger Control & Distribution System (TCDS)**

- upgrade of existing TTC control system for installation in 2014/5;
- distribution of LHC clock, trigger and commands, reception of synchronous detector status, ...

- **Pixel Front End Driver (pixFED)**

- new front end board to acquire data from the upgraded pixel detector, to be installed in 2016;
- 400Mbps digital optics, increased readout bandwidth to DAQ, increased processing capability

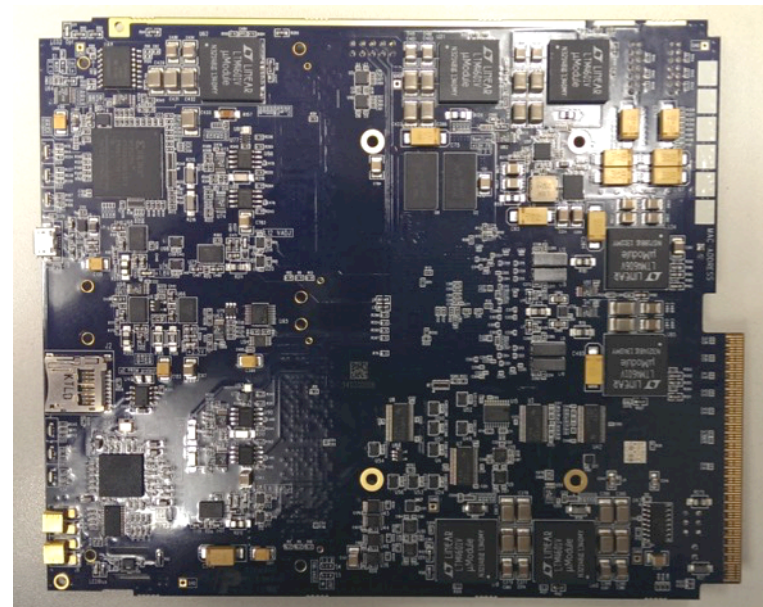
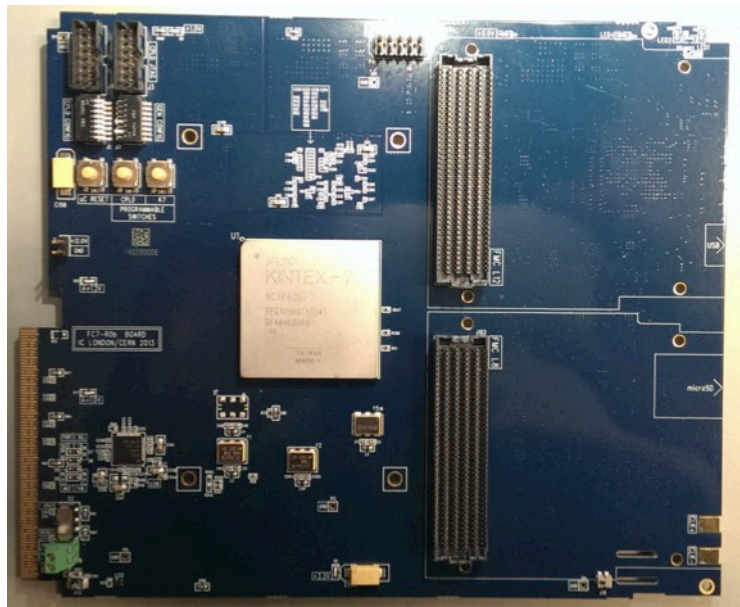

- 70pcs produced for TCDS, 30pcs more to come (for spares)
- Very high yield (> 95%)
- TCDS successfully commissioned in P5
- Huge experience gained integrating in CMS

- Few improvements in the FC7 design
- New PCB laminate: Megtron-6 (better manufacturability, Nelco turns obsolete)
- Procurement plan in place, with the same manufacturer as the FC7
  - 2pcs (prototypes) expected in December (*for CERN*)
  - 28pcs (pre-series) in January 2015 (*10pcs for Pixels + 3pcs for CERN, 15pcs for ICL*)
  - 40pcs (series #1) in Q1/Q2 2015 (*20pcs for Pixels, 5pcs for CERN, 15pcs for ICL*)
  - 50pcs (series#2) in Q3/Q4 2015 (*40pcs for Pixels, 10pcs for ICL*)
  - Option for up to additional 60pcs (*valid until Q3-2016*)

## WP3 objectives and status

- Calorimeter trigger for 2016
  - with commissioning in 2015
  - much better planning in place and pressure on US to meet commitments
    - several revisions of plan
  - good progress with MP7 deliveries
- D Newbold to report on status

# Brief mention of software

- Possibly does not do justice to large effort underway
  - with significant UK involvement

## CMS Online Software - Fall 2014

### Legacy

- P5 support
- TCDS
- XDAQ12

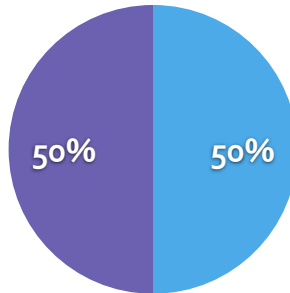

### Upgrade

- Stage 1
- Upgrade common software

Central Resources Only

Alessandro Thea

L1 Trigger Meeting

## CMS Common software

- Development continuing in the **background** of the other, more pressing activities
- Base features set defined
- Work ongoing...
  - Software interface for upgraded boards 'objects' consolidated
  - Reworking the control structure to insure the flexibility required by all parties.
  - Demonstrator using **AMC13 & MP7 core** software in the works
  - **Database structure defined**, stress tests in progress

Alessandro Thea

L1 Trigger Meeting

# 2016 Calorimeter Trigger Milestones

- **Milestones related to CTP7**

- 25.10.2014 3 CTP7s at CERN
- 15.11.2014 4 CTP7s at CERN (includes the previous)
- 20.01.2015 8 CTP7s at CERN (includes the previous)
- 28.01.2015 12 CTP7s at CERN (includes the previous)
- 25.03.2015 28 CTP7s at CERN (includes the previous)
- 08.04.2015 36 CTP7s at CERN (includes the previous)

- **Milestones related to commissioning of the trigger**

- 22.12.2014 Layer-2 – Patch Panel – Layer-1 Commissioned
- 16.01.2015 oSLB and HF uHTR systems commissioned
- 19.01.2015 Layer-2 – Patch Panel – Layer-1 Connected to uGT
- 25.11.2014 First Version of CTP7 firmware (incl. input playback)
- 09.03.2015 Final Version of CTP7 firmware (except DAQ link)
- 17.02.2015 Final design of Algorithms and data format defined
- Decision to upgrade 2016 trigger inputs from ECAL and HCAL
- 17.06.2015 B/E uHTR system connected to the trigger - Commissioned
- **02.09.2015 System ready for parallel data taking**

# MP7 order status

- Following prototyping/pre-production, two orders of 16 boards
  - 16 sufficient for Layer-2 but prudent to ensure successful manufacture
  - First 16 fully delivered (Hapro) + 2 from Exception, next batch under way
    - Further 8 ordered from Hapro, using parts in hand
  - Further Hapro order of 32 about to be launched
- Ensures other users are provided, and contingency for Cal trigger

<i>Project</i>	<i>Pre-prodn</i>	<i>Prod-1</i>	<i>Supp. Prod-1</i>	<i>Prod-2</i>	<i>Future req</i>	<i>Prod Total</i>
<i>Calo Trig Layer-2 &amp; demux</i>	9	25	5	4	12?	34-46
<i>GT &amp; GMT</i>	1	4	0	14	0	18
<i>Barrel Muon Track finder</i>	1	3	0	14	0	17
<i>Stage-1</i>	2	0	2	0	0	2
<i>LLR</i>	1	0	1	0	0	1
<i>Total required</i>	14	32	8	32	0	72-84
<i>Orders</i>	14	32	8	32	12?	72-84
<i>Delivery</i>	Done	Aug-Oct	Dec	Apr?	?	

# Future developments

- This activity spans both WPs and all groups
  - simulations to model data flow and performance
  - evaluation of track-trigger architecture
- Demonstrator within sight
  - TTMT architecture
    - already buildable with MP7s, as shown last time
  - algorithm designs for track finding
    - long term challenge but proof of principle desirable to establish specifications

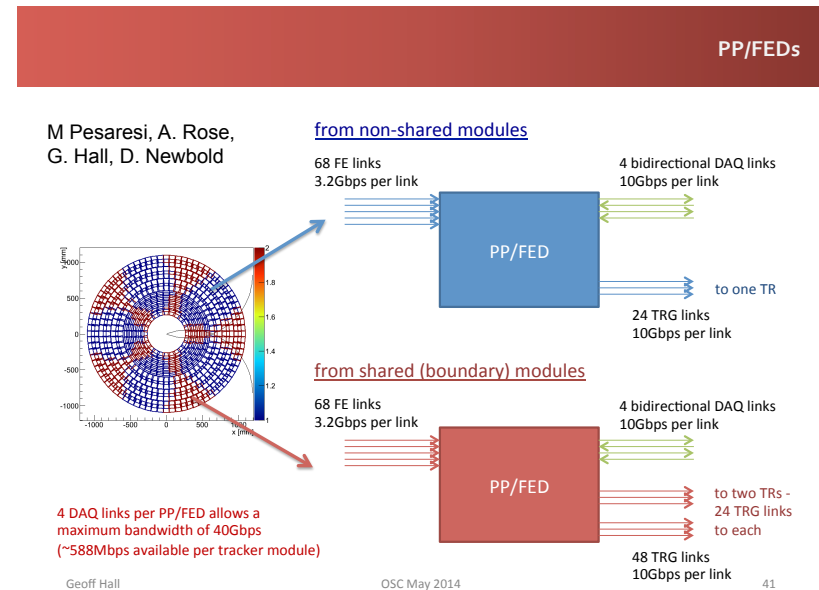

firmware based on pipelined systolic array  
proposed by Andy Rose

- early days!

locate series of hits on a trajectory, for which  $y = mx + c$   
point  $(m,c) \rightarrow$  line  $(x,y)$     point  $(x,y) \rightarrow$  line  $(m,c)$

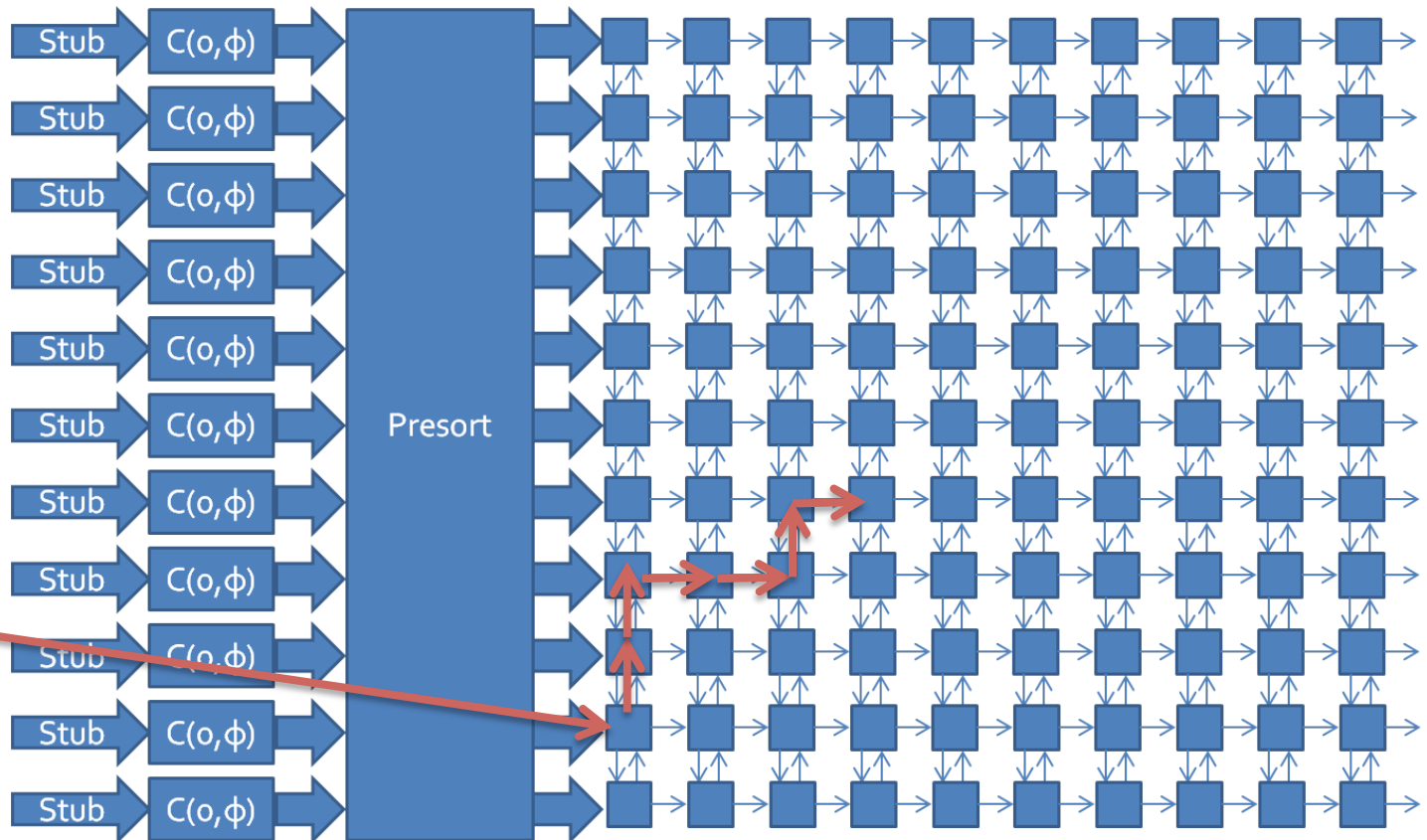

stub enters  
array, close to  
entry row and  
finds its way



# Per-Module Stub Distribution



Module Stubs Distribution (per module per event)

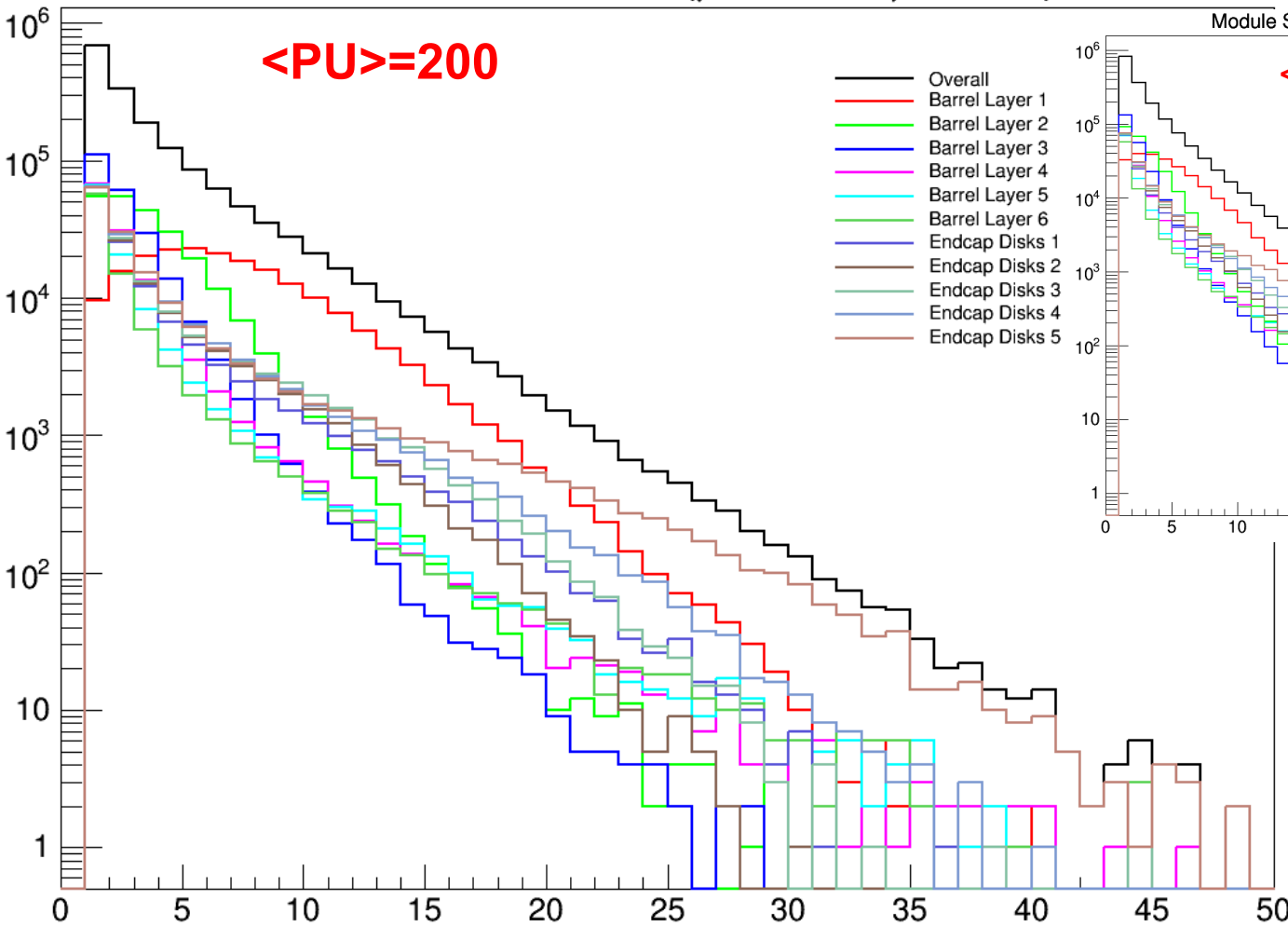

Module Stubs Distribution (per module per event)

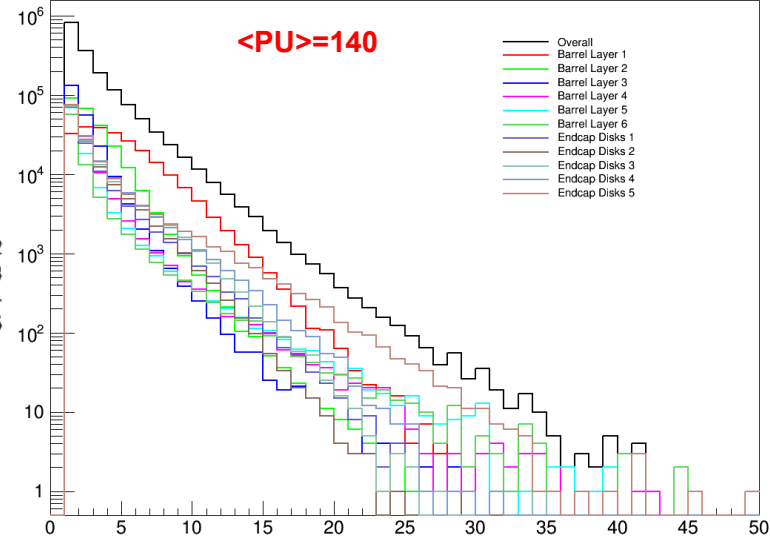

- Expenditure
  - Staff expenditure essentially as foreseen
    - slower than originally expected at RAL TD, but by our delivery plan
  - Travel also as foreseen – further LTA commitments under way
- Materials & equipment
  - WP2: FC7 commitments to prototyping, pre-production and future project use
    - further CBC manufacture probably late 2015, so invoiced expenditure 2016
  - WP3: MP7 orders plus optical components, crates, fibres, patch panels, etc
  - Invoices follow slowly, so financial table does not give complete picture
    - Significant purchases via CERN
    - Now believe we have found solution to place orders paid from Imperial grant
      - slightly less clear for costs incurred elsewhere in UK, but minor issue
  - Overall commitments ~£400k

# Conclusions

- Milestones
  - reported in document, and recent trigger milestones listed earlier
- Risks
  - register revised
  - discussion of key issues in report
- Trigger project entering crucial commissioning phase
  - main questions still concern US deliverables
    - otherwise continued good progress with all parts of UK upgrade project
  - CMS objective, identical to UK, to deliver TDR trigger for 2016 operation
    - significant UK investment (including support to other CMS users)
    - would like OSC to take note, and endorse our actions
      - next talk to provide details
    - could be wise for OSC independently to confirm CMS strategy and seek recognition of UK effort and commitments in view of Trigger status review in January 2015

Further information

# Intermediate trigger - 2015

- Limited to use current RCT and current GT

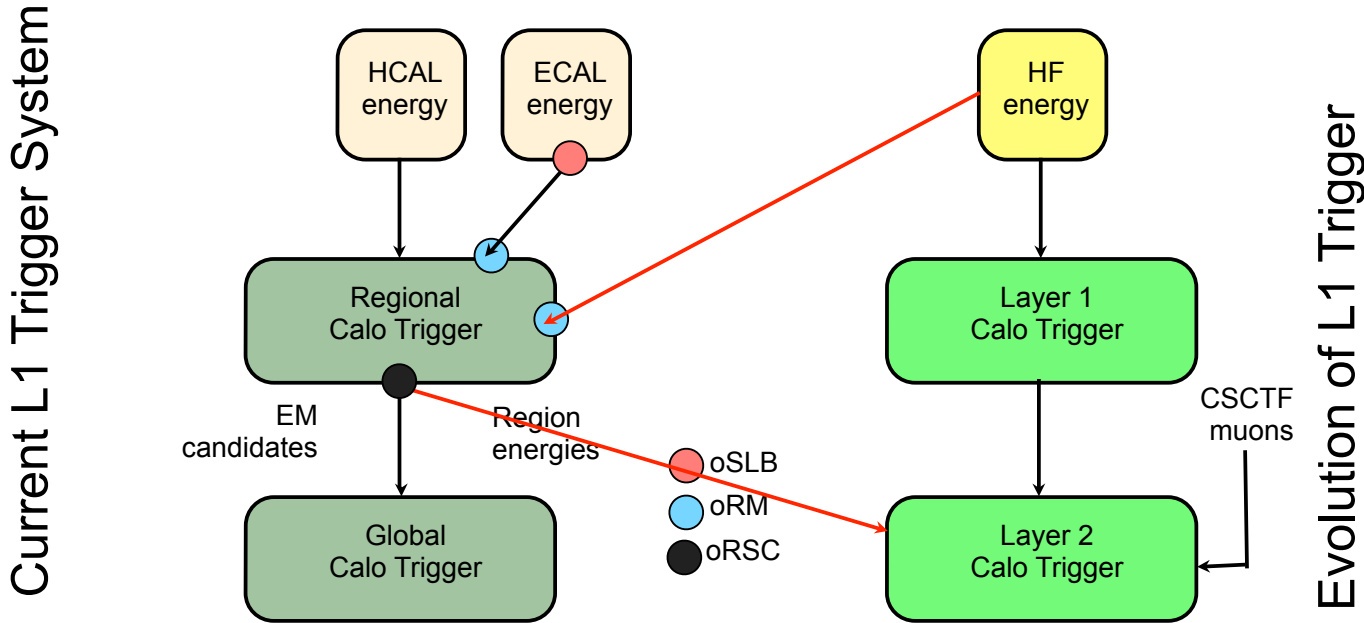

- Significant performance improvements possible in  $e\gamma$ ,  $\tau$  and jets
- Prototype processor cards and (new) oRSC cards to duplicate signals
- Retains data to legacy GCT for easy rollback with just reconfiguration

# V4.1e

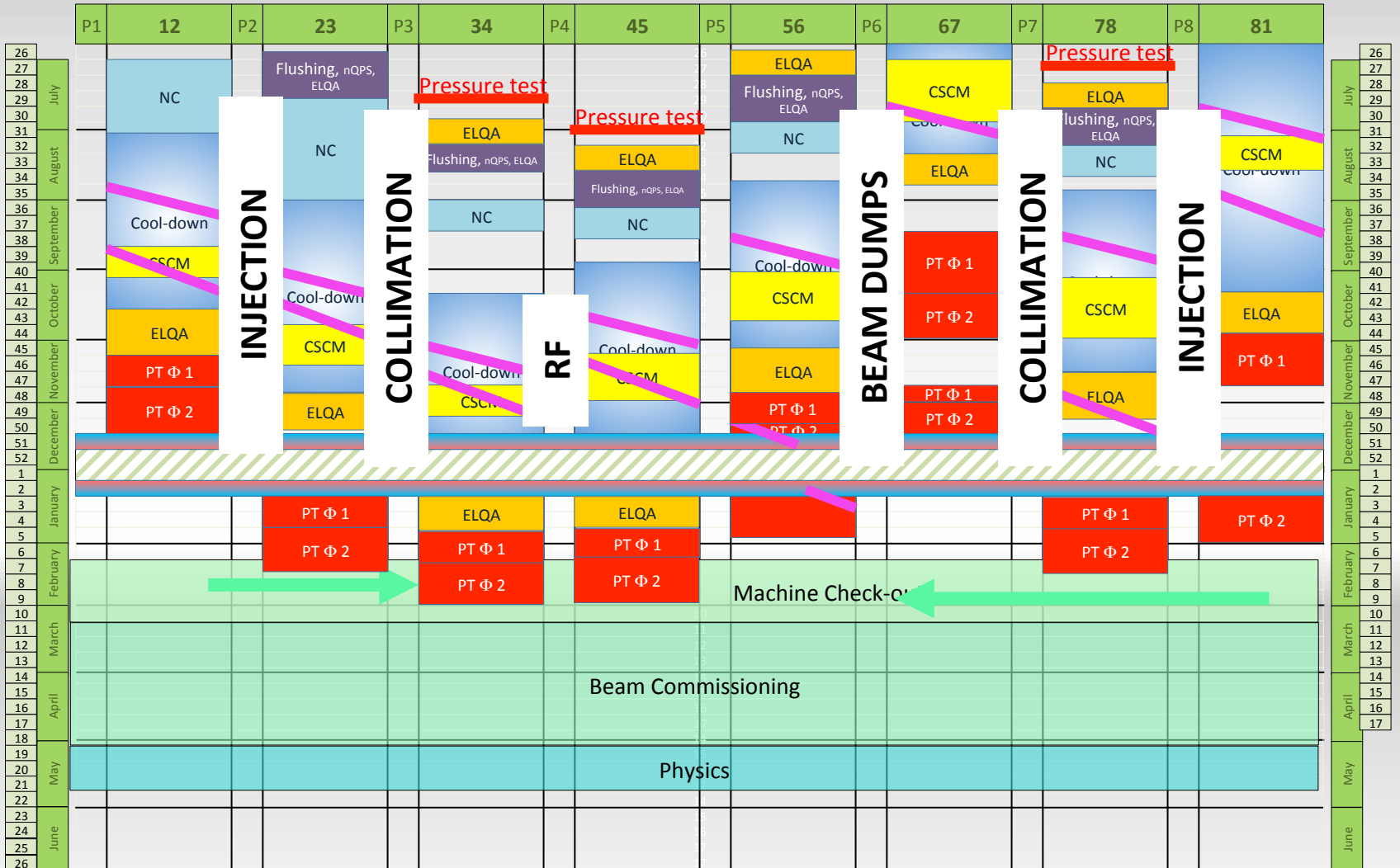
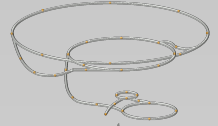

# 2015 version 0.5

Phase	Days
Initial Commissioning	56
Scrubbing	23
Early special physics run (LHCf/VdM)	5
<b>Proton physics 50 ns</b>	<b>7 + 21</b>
<b>Proton physics 25 ns – phase 1</b>	<b>44</b>
<b>Change in beta*</b>	<b>5</b>
<b>Proton physics phase 2 (including ramp-up)</b>	<b>44</b>
Special physics runs (TOTEM/VdM)	7
Intermediate energy run - to be scheduled	
Machine development	19
Technical stops	15
Technical stop recovery	6
Ion setup/Ion run	4 + 24
<b>Total</b>	<b>280 (40 weeks)</b>

# CBC3 design progress at RAL

Mark Prydderch, Michelle Key-Charriere, Davide Braga

- SRAM cell status
  - SRAM cell has been re-designed - PMOS switches and enclosed NMOS
- I2C cell SEU sensitivity
  - improving hardness of triplicated logic means increased size to keep storage cells further apart
  - SEU resistant Whitaker cell used in pipeline not much larger
  - currently propose to look at replacing I2C storage cells with this
- correlation/stub finding logic with  $\frac{1}{2}$  strip resolution
  - completed at coding and circuit level for 5 bit bend info generation
  - awaiting decision on bend info changes before proceeding to layout
- logic for transferring 3 stub addresses to data assembly circuitry completed to layout stage
- data assembly circuitry currently under design
- CBC3 specification document almost complete - needs choice of bend info
- top level simulation constructed to verify synchronization of data from different time domains

with a single custom FMC, the FC7 can fully satisfy the role of the pixel FED

## 2x 12 channel parallel pluggable optical receivers (Fitel)

- running at 400Mbps, reads in data directly from detector

## SFP+/QSFP+ required for DAQ (not pictured)

- 10Gbps readout, to be prototyped

total **70 boards** required for pixFED, possibly more

with the TCDS FMC, the FC7 could also satisfy the role of the pixel Front End Controller (FEC)

nothing special required, R&D ongoing

~**30 boards** required for pixFEC

