

## CMS plans for the next phases of the LHC

---

21 July 2014

University of Bristol  
Brunel University  
Imperial College London  
Rutherford Appleton Laboratory

Geoff Hall

# CMS Upgrades

- Brief reminder of the background
  - Timing and scope of planning
  - Main physics objectives
  - CMS detector requirements and UK activities
- Phase I upgrade under way and growing focus on HL-LHC
  - likely overall Phase II cost of ~300 MCHF, in European accounting
    - significant concerns from agencies about their ability to fund
  - a more concrete plan is needed, with leadership from CERN
    - this makes some future projections a bit tricky
- From a UK perspective
  - UK role and likely commitments not yet fully decided but significant momentum from existing R&D over last 5 years
    - convergence around trigger, tracker and DAQ related activities
    - hardware effort fully complements physics interests

# European Strategy for Particle Physics - update 2013

- **High-priority large-scale scientific activities**
- ... four activities have been identified as carrying the highest priority.
- The discovery of the **Higgs boson** is the start of a major programme of work
  - to measure [its] **properties** with the highest possible **precision**
  - for testing the **validity of the Standard Model**
  - to **search for further new physics** at the energy frontier.
- **The LHC is in a unique position to pursue this programme**
- Europe's **top priority** should be exploitation of the full potential of the LHC
  - **high-luminosity upgrade** of the machine and detectors
  - collecting **ten times more data** than the initial design, by around 2030
  - exciting opportunities for study of **flavour physics and quark-gluon plasma**

# LHC schedule beyond LS1

LS2 starting in 2018 (July) => 18 months + 3 months BC  
 LS3 LHC: starting in 2023 => 30 months + 3 months BC  
 Injectors: in 2024 => 13 months + 3 months BC

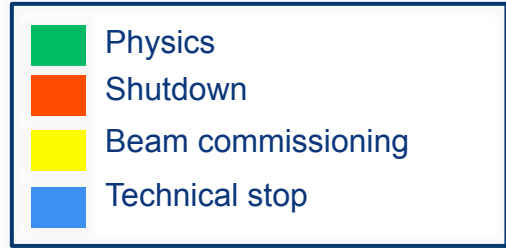

30 fb<sup>-1</sup>

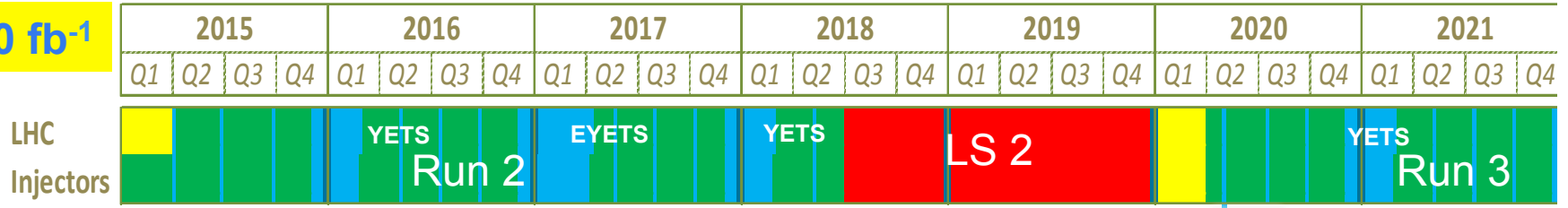

300 fb<sup>-1</sup>

ATLAS & CMS

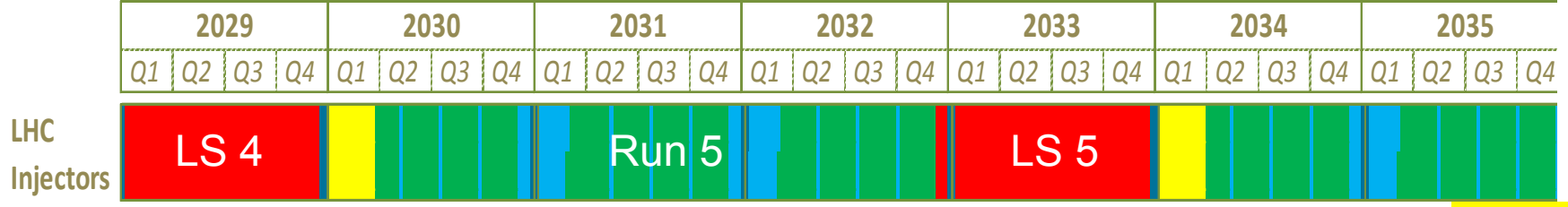

3'000 fb<sup>-1</sup>

(Extended) Year End Technical Stop: (E)YETS

# Motives for upgrades

- Many big physics questions outstanding
  - perhaps improving the Higgs precision will be the only way?
    - experimentally challenging – both for detectors and analyses
  - if SUSY is discovered in Run 2, may expect some revision of plans
- but probably unwise to assume today's experimental and theoretical landscape will be static
  - LHC machine and experiments have been running only three years
  - cf C Quigg 20 questions at IoP 2014
- Some important parts of detectors will be under great stress during next decade
  - radiation damage
  - data volumes and rates, trigger
  - performance improvement can be gained from technology evolution
- By 300-500 fb<sup>-1</sup> (~2023) major upgrade is essential

# The SM is incomplete: big questions

Dark matter?

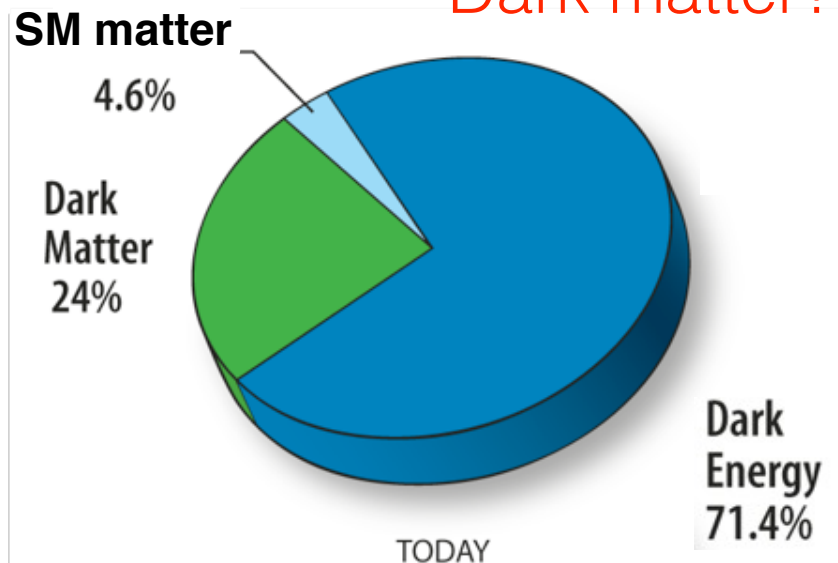

Fine-tuning?

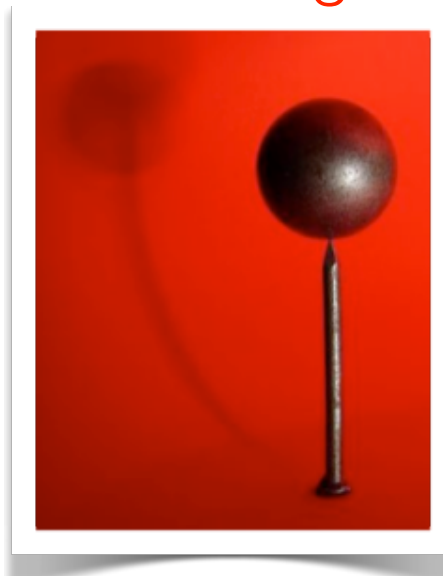

Origin of SM matter and flavor?

$$Y_U \approx \begin{pmatrix} 10^{-5} & -0.002 & 0.007 + 0.004i \\ 10^{-6} & 0.007 & -0.04 + 0.0008i \\ 10^{-8} + 10^{-7}i & 0.0003 & 0.92 \end{pmatrix}$$

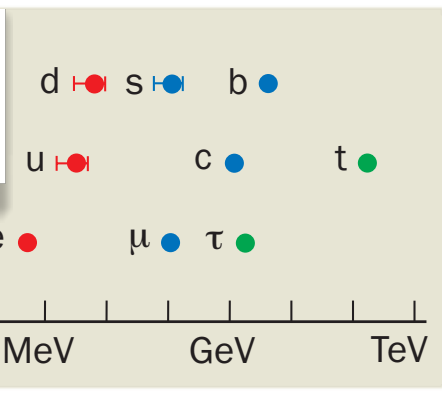

Unity of forces?

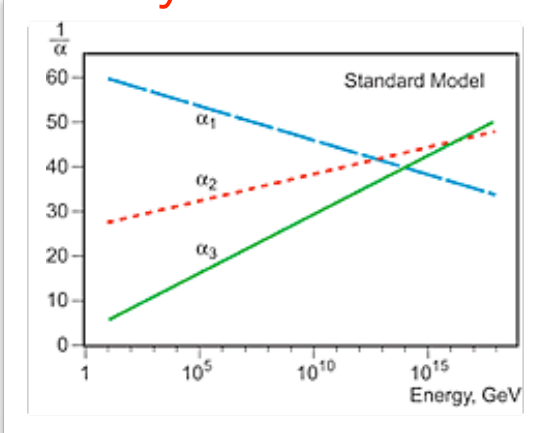

# What does 14 TeV @3000fb<sup>-1</sup> bring?

ATLAS Preliminary (Simulation)

$\sqrt{s} = 14 \text{ TeV}$ :  $\int L dt = 300 \text{ fb}^{-1}$ ;  $\int L dt = 3000 \text{ fb}^{-1}$

$\int L dt = 300 \text{ fb}^{-1}$  extrapolated from 7+8 TeV

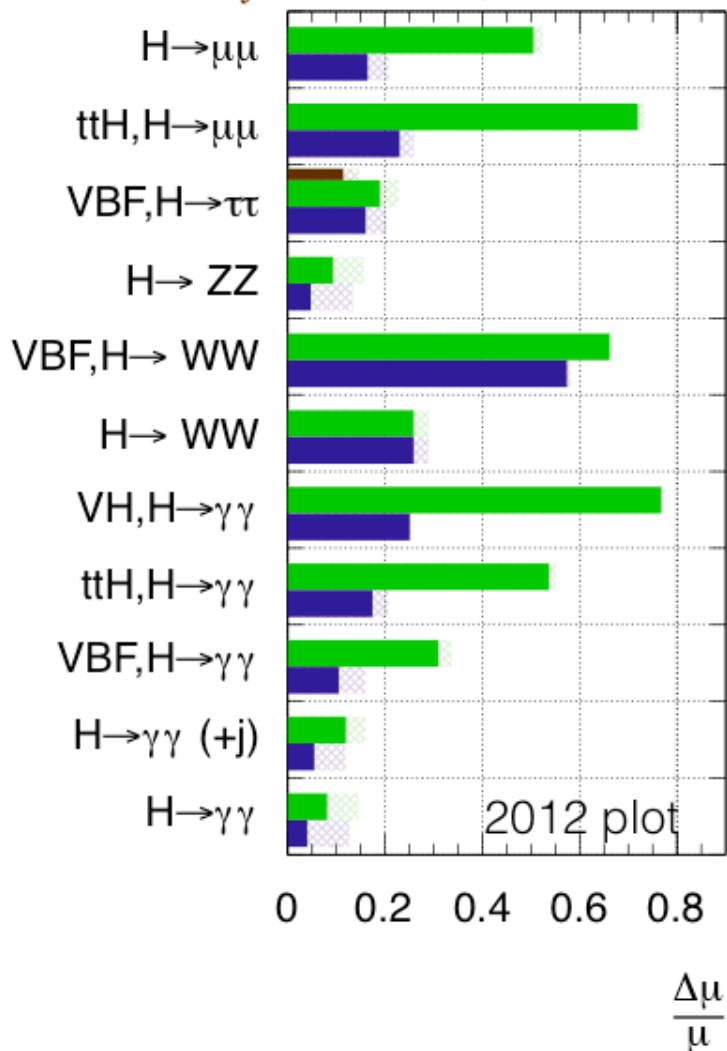

arXiv:1307.7135

Table 2: Precision on the measurements of the signal strength for a SM-like Higgs boson. These values are obtained at  $\sqrt{s} = 14 \text{ TeV}$  using an integrated dataset of 300 and 3000 fb<sup>-1</sup>. Numbers in brackets are % uncertainties on

[ no theory uncertainty, present theory uncertainty ]

L (fb <sup>-1</sup> )	H → γγ	H → WW	H → ZZ	H → bb
300	[6, 12]	[6, 11]	[7, 11]	[11, 14]
3000	[4, 8]	[4, 7]	[4, 7]	[5, 7]

H → ττ	H → Zγ	H → inv.
[8, 14]	[62, 62]	[17, 28]
[5, 8]	[20, 24]	[6, 17]

# What does 14 TeV @3000fb<sup>-1</sup> bring?

- Increased precision on existing channels

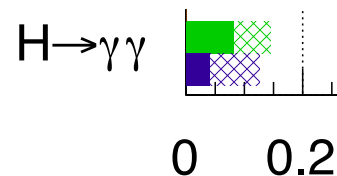

H → ZZ
[7, 11]
[4, 7]

- Observation of rare decays Zγ, μ<sup>+</sup>μ<sup>-</sup>, cc
- Double Higgs production
- Longitudinal Vector-Boson Scattering



H → μμ



3000fb<sup>-1</sup> at 14TeV offers new possibilities

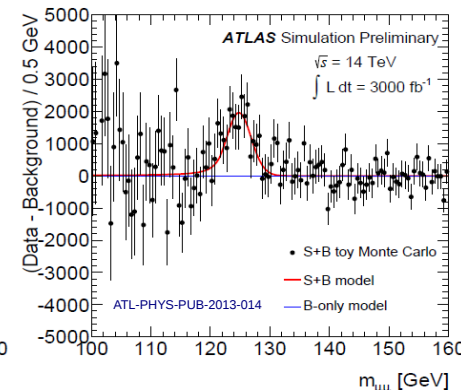
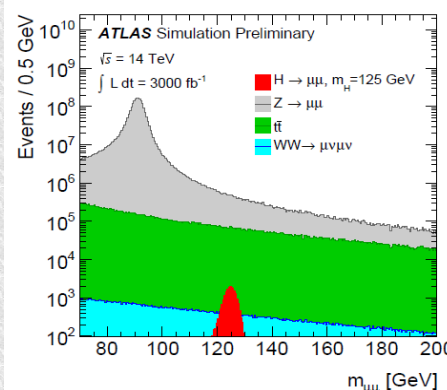

- H → μμ
  - Allows direct study of coupling to two different leptons
  - Test lepton flavour-violation carefully

W.Murray STFC/Warwick 19

# Physics programme and motivation

- SUSY may be found in Run 2
  - but may not be
  - why should this be a disappointment? (although discoveries are exciting)
- Particle physics has gone through many periods of consolidation
  - e.g. post-charm and realisation of its significance
  - search for heavier quarks, search for IVB (W & Z), establishment of number of generations, search for Higgs
    - $\nu$  sector is fascinating, but partly because of SM and discoveries elsewhere
  - the LHC and the experiments have been incredibly successful
    - in a remarkably short period of operation
  - the theoretical dust has not settled
    - new ideas will surely emerge, a new scalar field is unprecedented
  - precise measurement of Higgs couplings is not a trivial programme
- maintaining CERN and major accelerator developments are vital

# CMS Upgrade programme in a nutshell

## Complete detector for nominal LHC conditions $\langle \text{PU} \rangle \sim 25$

- Muon 4<sup>th</sup> endcap station, RO of CSC ME1/1 & DTs
- Replace HCAL HF and HO photo-detectors and HF backend electronics
- Tracker operation at  $-20^{\circ}\text{C}$
- Prepare and install slices of Phase 1 upgrades
- L1 trigger upgrades for 2016

## Phase 1 upgrades: $\langle \text{PU} \rangle \sim 40$

- New L1-trigger systems (Calorimeter - Muons – Global) continue
- New Pixel detector (installation in 2016/17 Year End Technical Stop)
- HCAL upgrade: photodetectors and electronics

## Phase 2 upgrades: $\langle \text{PU} \rangle \sim 140 - 200$

- Replace detector systems whose performance is significantly degrading due to radiation damage
- Maintain physics performance at this very high PU

LS1  
2013-14

LS2  
2018-19

LS3  
2023-25

# Phase I trigger upgrade

- UK has leading role in calorimeter trigger upgrade
  - state of the art processing board developed: MP7
  - new concept for trigger developed: Time Multiplexing
- Hardware upgrade is on course to be in operation by 2016
  - depending on external factors, may be operating in 2015
- Original trigger designed for pileup of  $\sim 25$  @  $10^{34} \text{ cm}^{-2}\text{s}^{-1}$  40 MHz
  - pileup already exceeded that in Run 1 @ 20MHz
  - luminosity will exceed  $10^{34}$  in Run 2
- Significant gains from exploiting calorimeter granularity and resolution, and to manage pileup
  - upgrades needed to transmit the data
  - and new processing hardware to keep pace – hence MP7
    - NB this kind of firmware is not easy, and UK efforts are leading this in CMS

# CMS Phase 1 Upgrade of L1 Trigger

- Hardware based on powerful FPGAs and high bandwidth optics
  - Calorimeter, Muon and Global triggers built with few board types, all using Virtex 7 FPGA
  - Improved algorithms for PU mitigation and isolation
  - Trigger inputs split during LS1 to commission new trigger in 2015 in parallel with operating system

Current L1 Trigger System

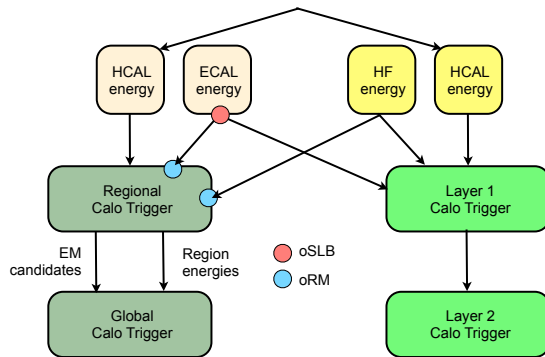

Optical splitting for parallel commissioning, calorimeter trigger

transmit finer granularity calorimeter information = more bits

Upgrade L1 Trigger System

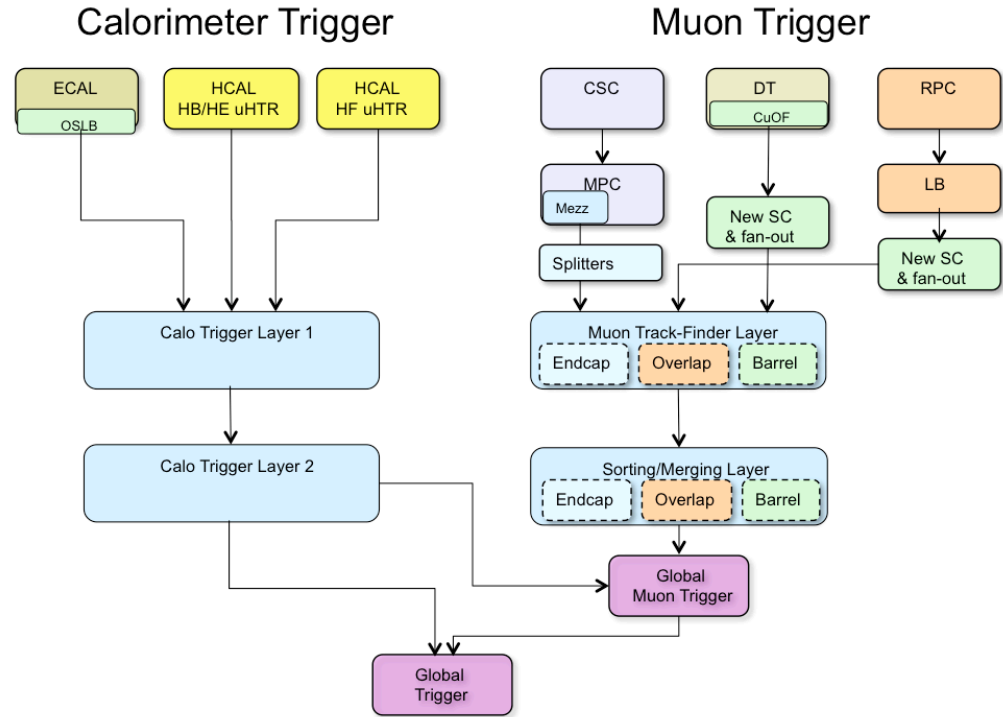

Level 1 Trigger Upgrade

# Conventional versus TM Trigger Architecture

This concept looks increasingly attractive:  
flexible and powerful, cost effective,...

## Conventional (Regional)

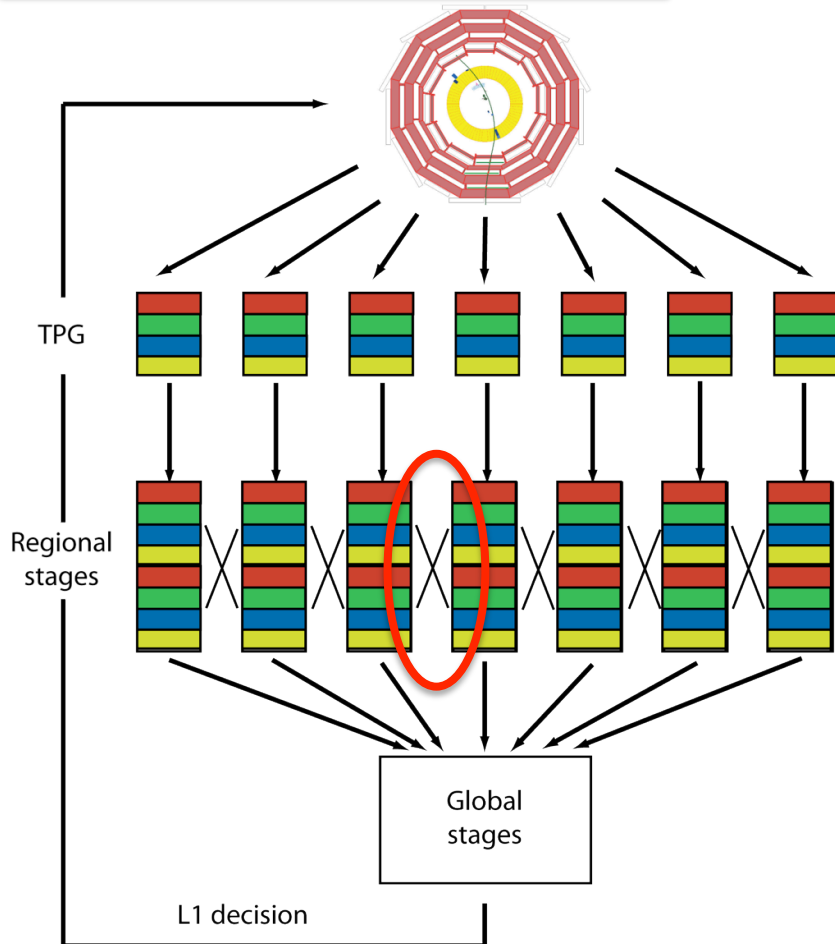

## Time Multiplexed

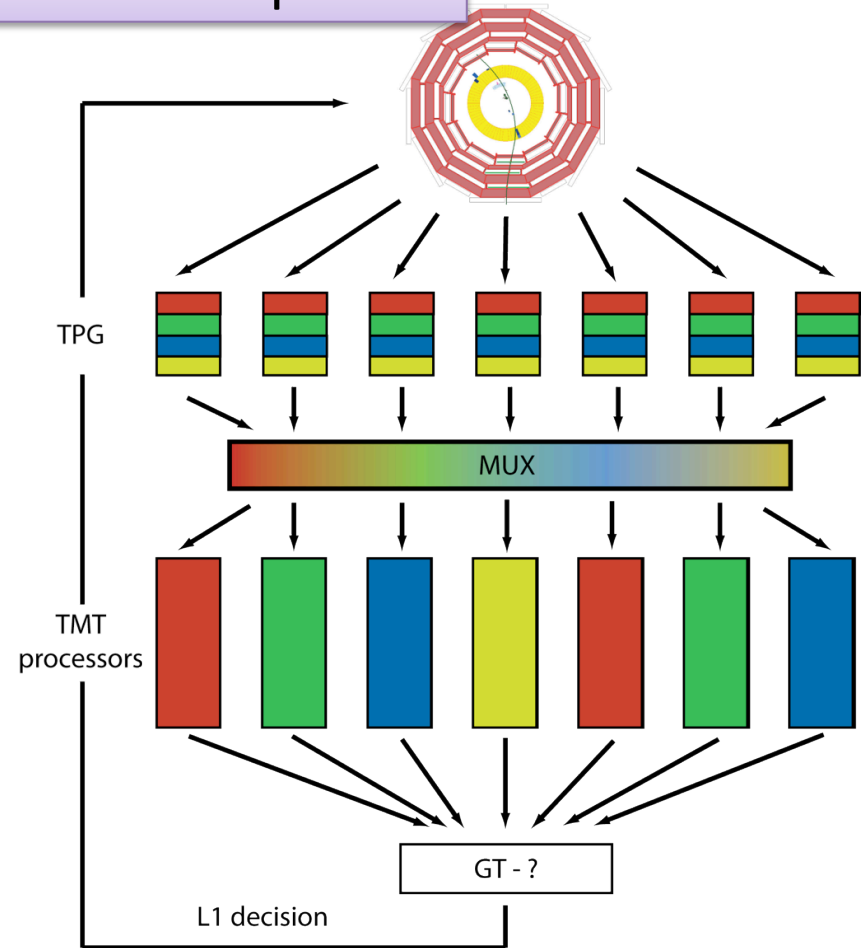

- **72 input/72 output** optical links

- all links operate at **12.5 Gbps**  
(10 Gbps in CMS)

- total bandwidth **> 0.9 Tbps**

tested, currently in production

algorithm development well advanced

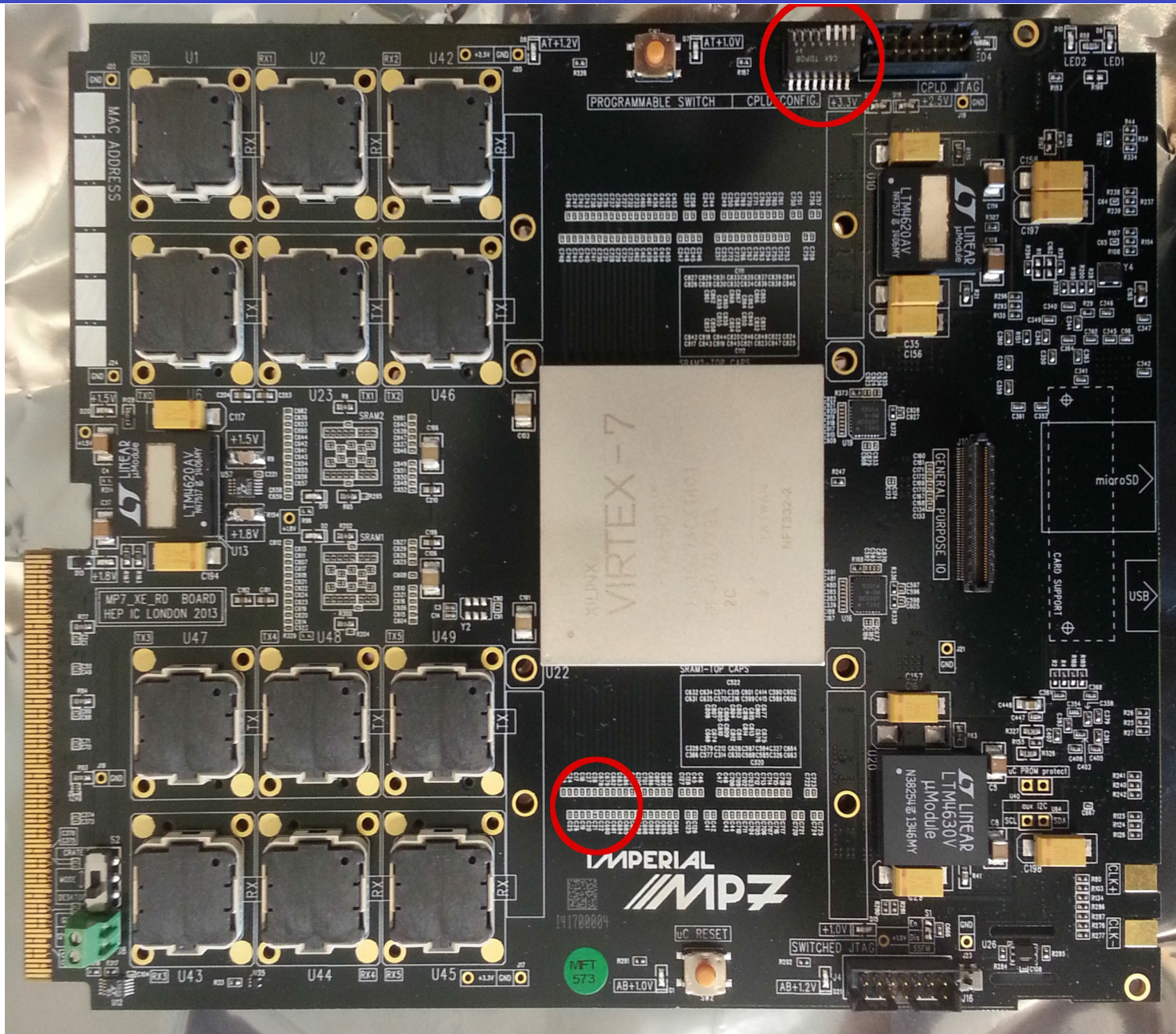

# eg: Current status of TMT jet algorithms

- Jets: essentially equivalent to HLT anti- $k_t$  algorithms
  - 9×9 sum of trigger towers at every site
  - Fully asymmetric jet veto calculation
  - Local (“Donut”) or Global pile-up estimation
  - Full overlap filtering
  - Pile-up subtraction
  - Pipelined sort of candidates in  $\phi$
  - Accumulating pipelined sort of candidates in  $\eta$
- Ring sums
  - Scalar and Vector (“Missing”) ET
  - Scalar and Vector (“Missing”) HT

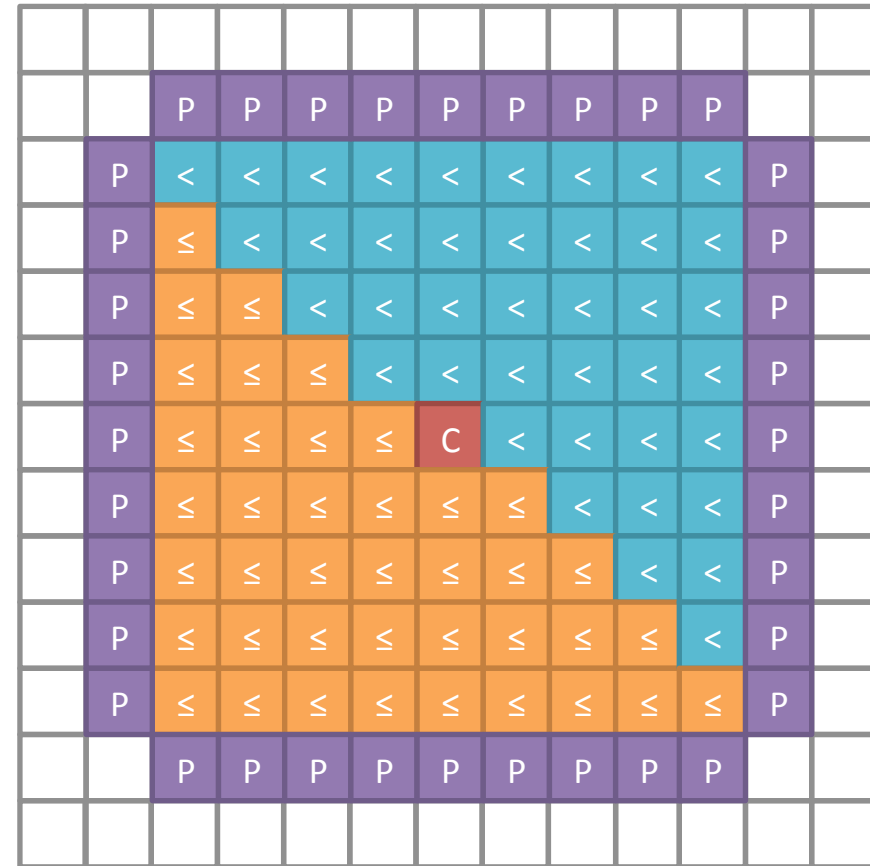

9×9 jet at tower-level resolution

<45% LUT utilization INCLUDING links , buffers, control, DAQ, etc.  
Runs at 240 MHz

- Experiments must maintain full sensitivity for discovery and precision measurements at low  $p_T$ , under severe conditions
- Pileup
  - $\langle \text{PU} \rangle$  will approach 50 events per crossing by **LS2**
  - $\langle \text{PU} \rangle \approx 60$  by **LS3**
  - $\langle \text{PU} \rangle$  up to 140 at **HL-LHC**
- Radiation damage
  - Light loss (calorimeters), increased leakage current (silicon detectors)
  - Requires work to maintain calibration
  - And eventually limits the performance-lifetime of the detectors

This will be a very typical event

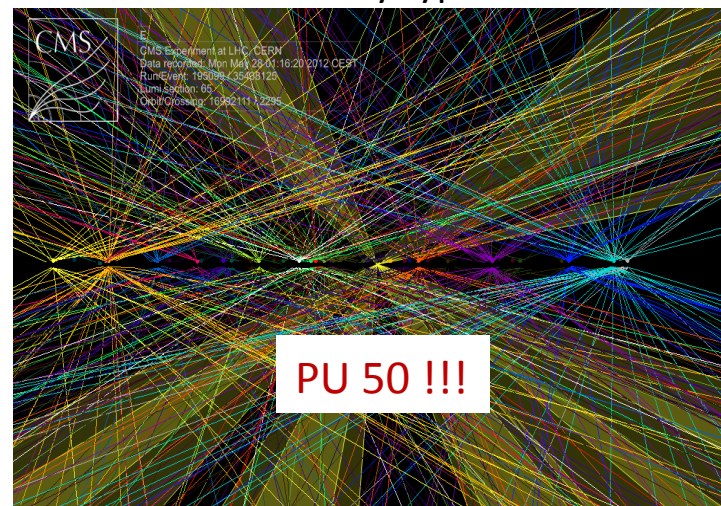

Observed signal loss in HF quartz fibers,  
2011+2012 Laser data vs Radiation dose

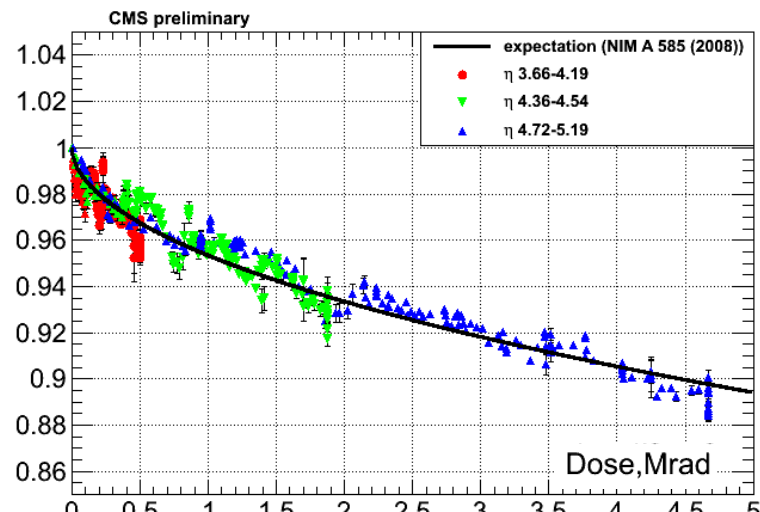

# Motivations for upgrade

## ➤ Longevity of Outer Tracker

to be included in TP

Tomas Hreus 17.03.2014

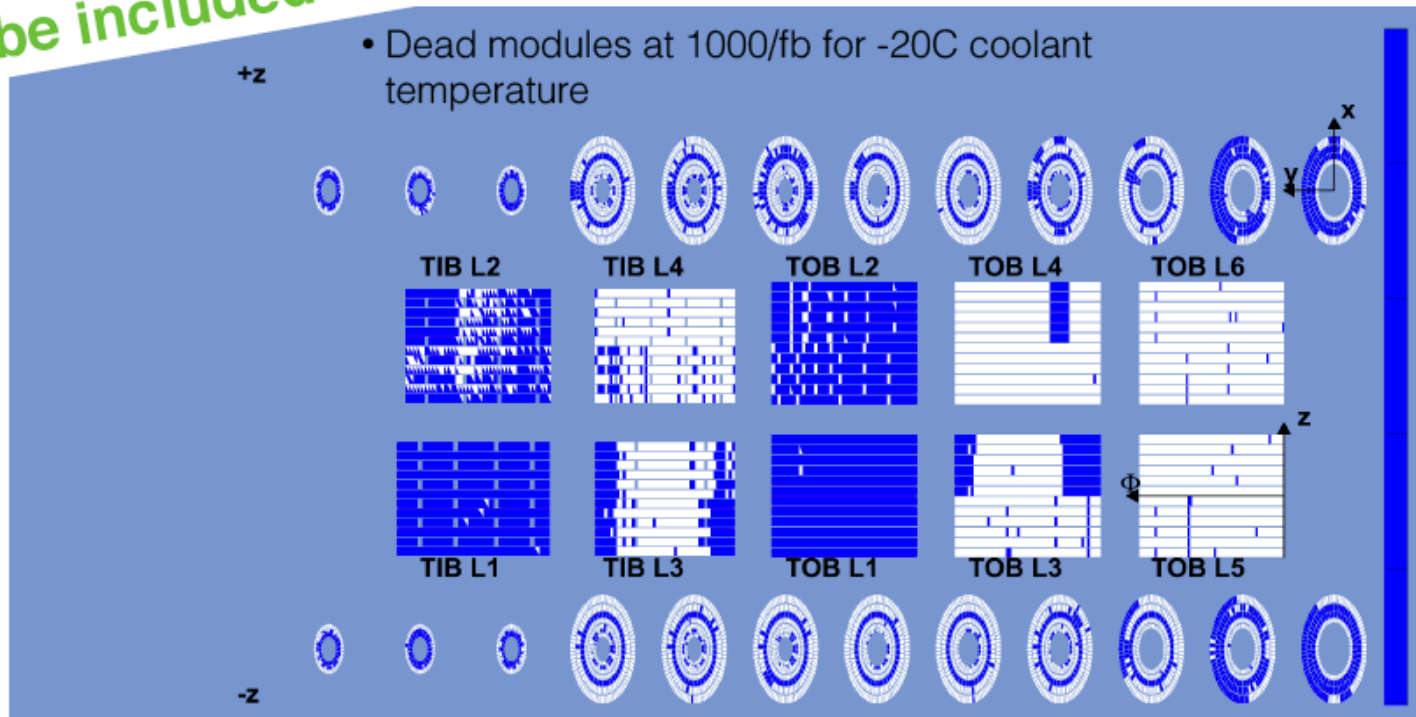

- Blue = dead modules (including present ones)
- all modules with present cooling issues, TIB L1/2, TOB L1/2 + TEC R5 (thick modules)

NB these ideas originated and were justified over several years by UK - now CMS dogma

# CMS Phase II Outer Tracker design

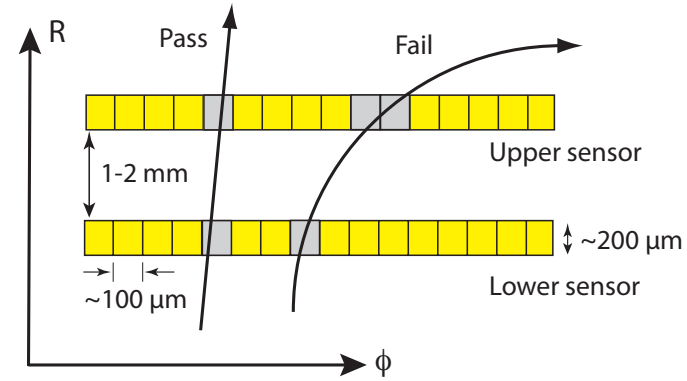
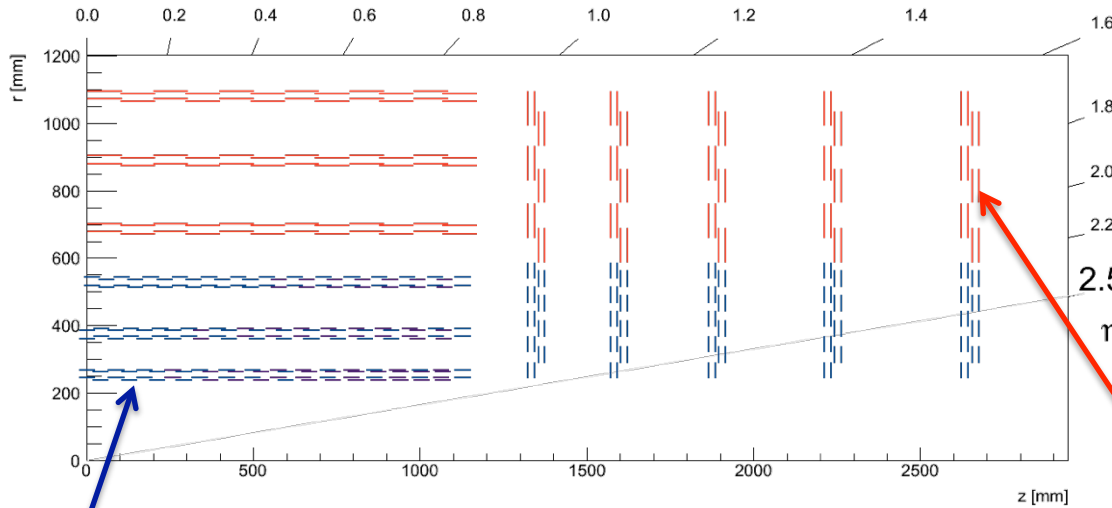

- ~15000 modules transmitting
  - $p_T$ -stubs to L1 trigger @ 40 MHz
  - full hit data to HLT @ 0.5-1 MHz

~7100 PS-modules

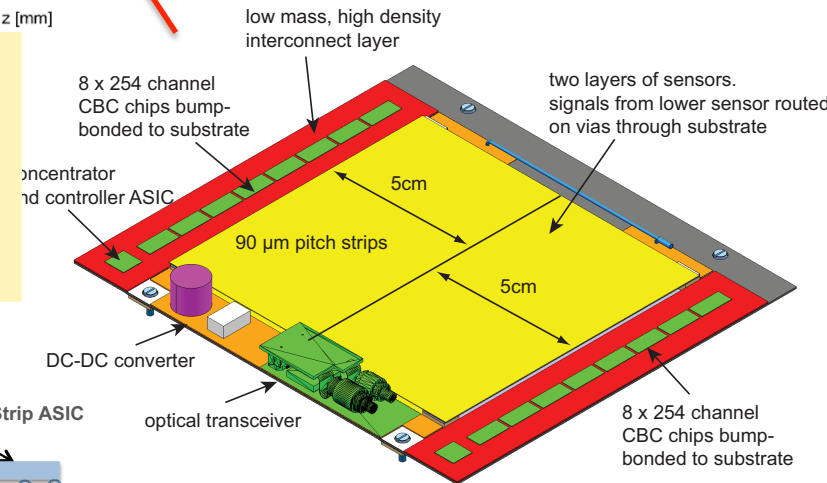
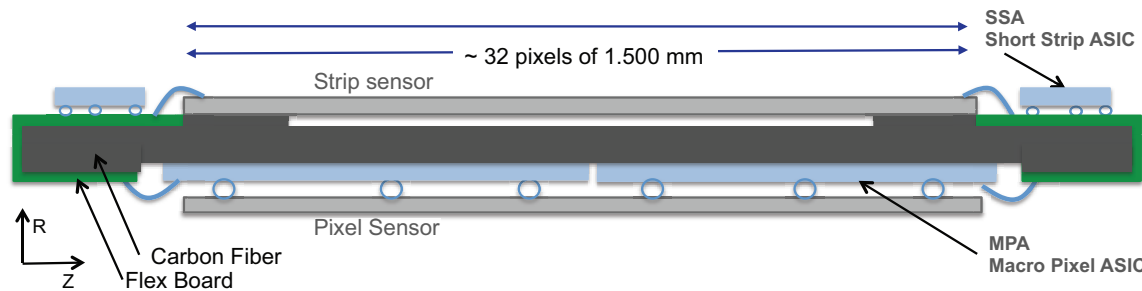

~8400 2S-modules

# Motivations for upgrade

- Track finding (nearly) “out of the box”

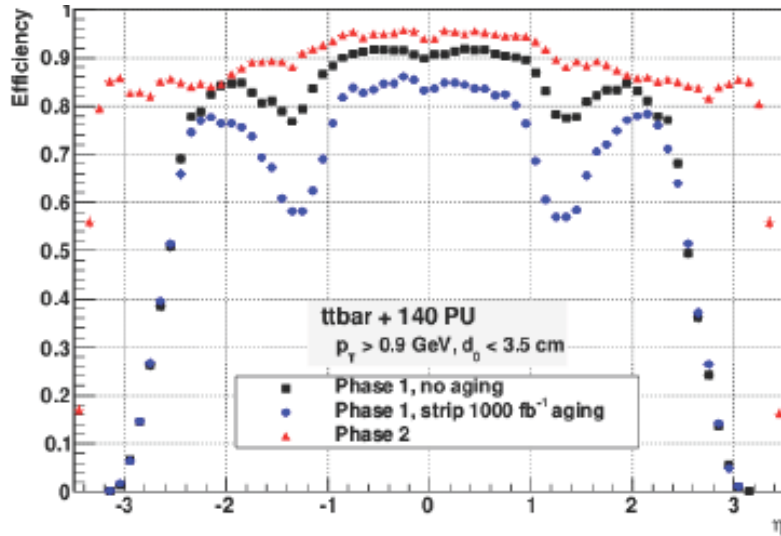

Tomas Hreus 17.03.2014

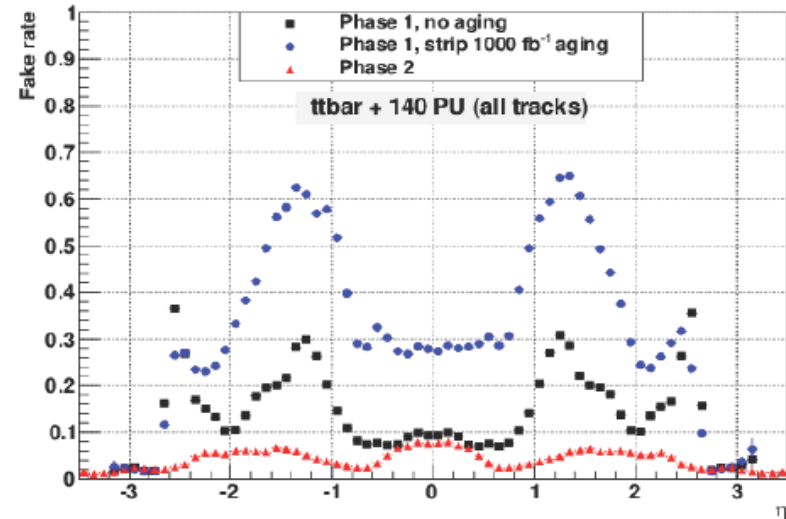

- Demonstrates effect of Outer Tracker aging
  - ⊙ And the power of the high-granularity upgraded tracker!

- To be complemented with effect of readout inefficiency in the pixels

# CMS gains from Track-trigger for $\mu$ , e Triggers

(over Phase 1 Trigger,  $|\eta| < 1$ )

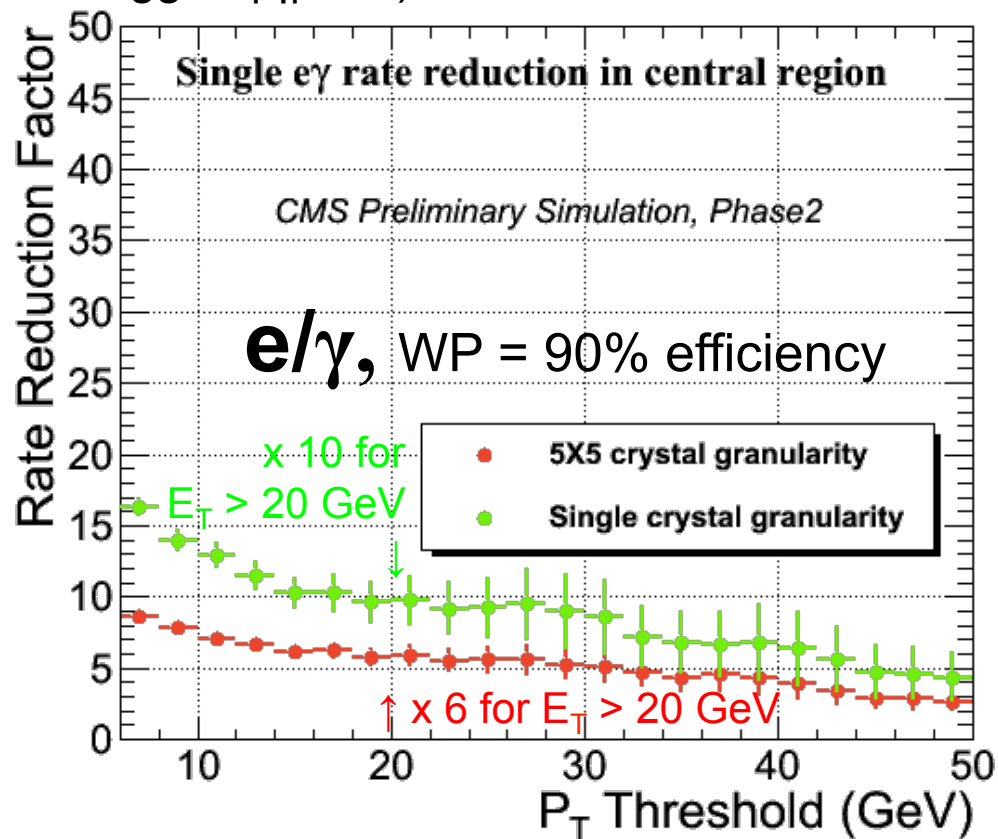
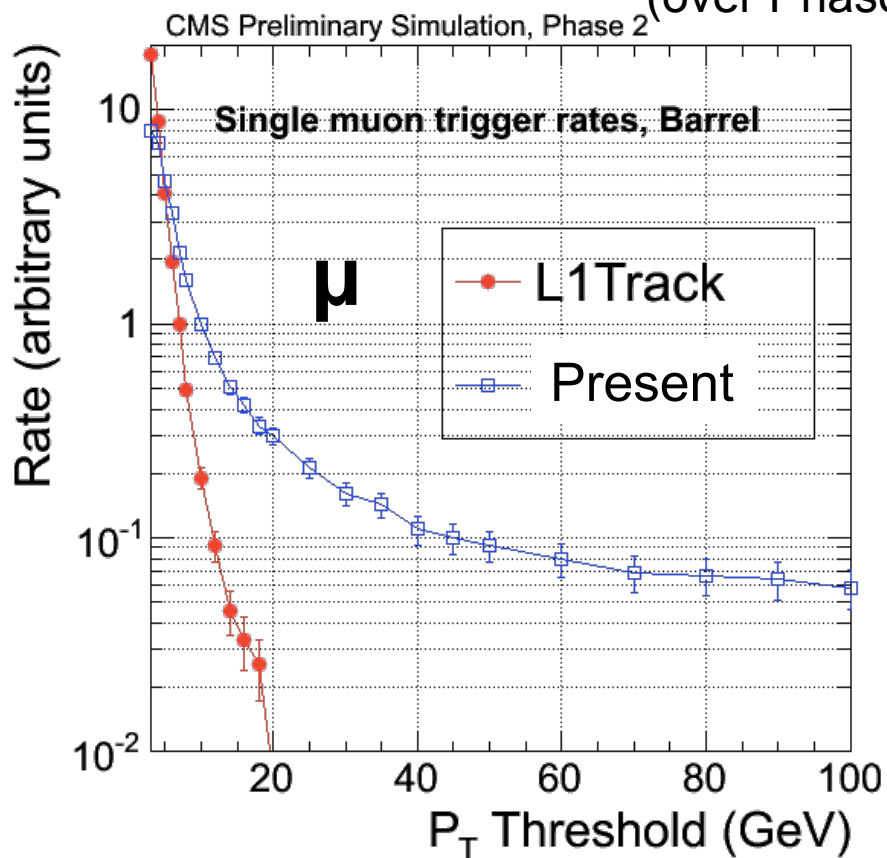

Matching Drift Tube trigger primitives  
with L1Tracks: **large rate reduction:**  
Removes flattening at high  $P_t$

**Rate reduction** by matching L1  $e/\gamma$   
to L1Track stubs for  $|\eta| < 1$ .

Red: with current (5x5 xtal) L1Cal granularity.

Green : using single crystal-level position resolution  
improves matching

# Outer Tracker electronics

## ➤ Description of architecture

- ⊙ Benchmarks: stubs with  $p_T > 2$  GeV, @ 40 MHz, L1 accept rate > 500 kHz,  $\langle \text{PU} \rangle < 140$

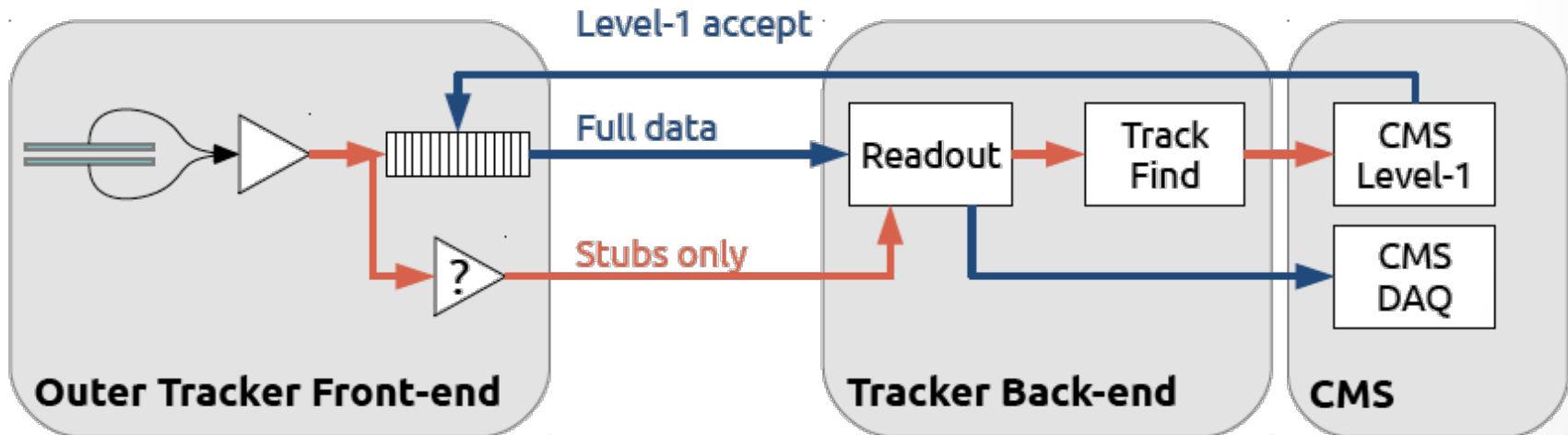

# Tracking

## ➤ Resolution

- ⊙ Full sim confirms a priori estimates!

[1-200] GeV muons, full simulation

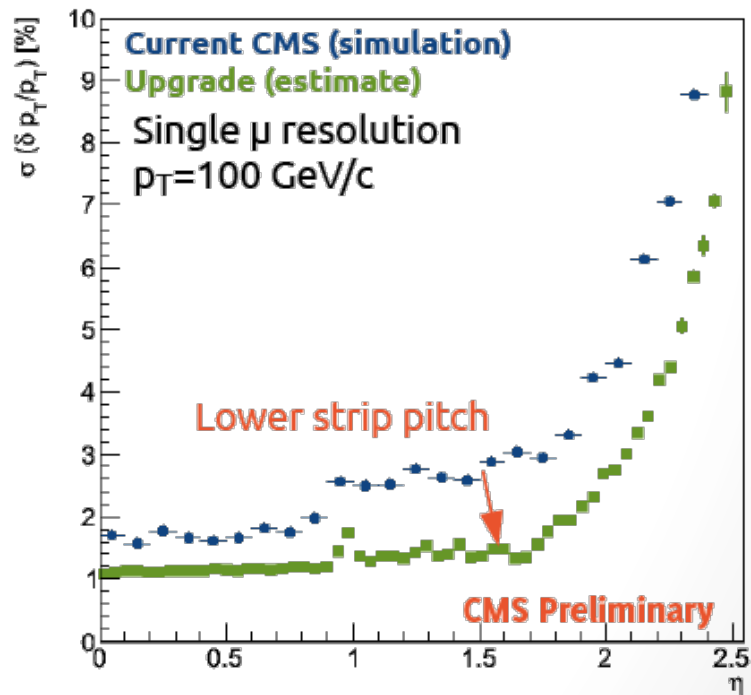
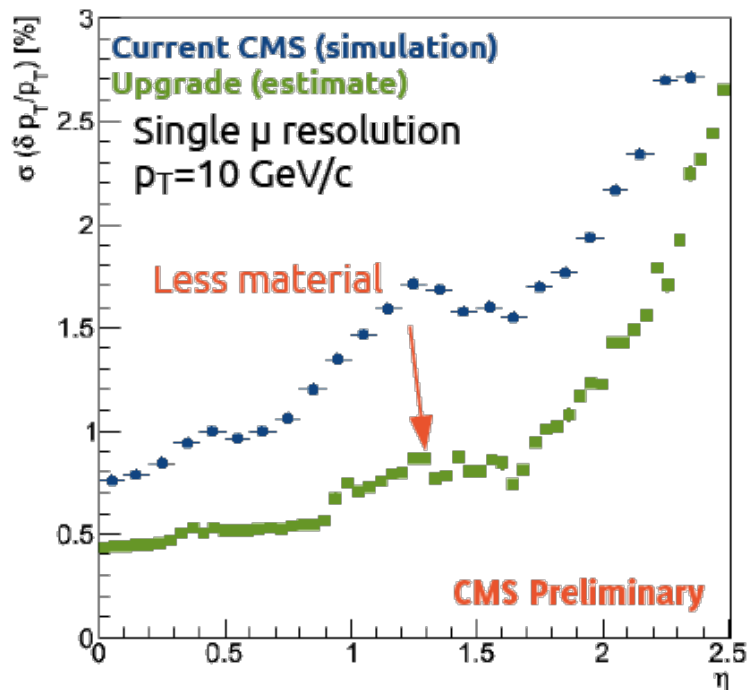
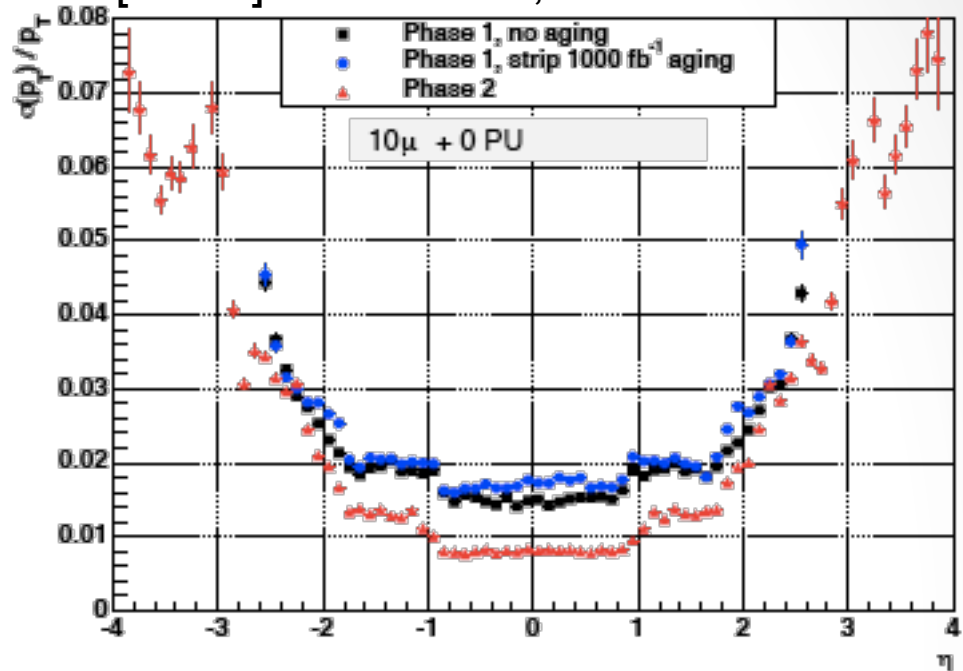

# Endcaps: further CMS challenge

- Endcap Calorimeters require replacement because of radiation damage
  - and are vitally important for physics programme
  - UK role in construction, operation and physics so a natural interest if resources permit
- EITHER build EE towers in eg. Shashlik design (crystal scintillator: LYSO, CeF)
  - Rebuild HE with more fibers, rad-hard scintillators

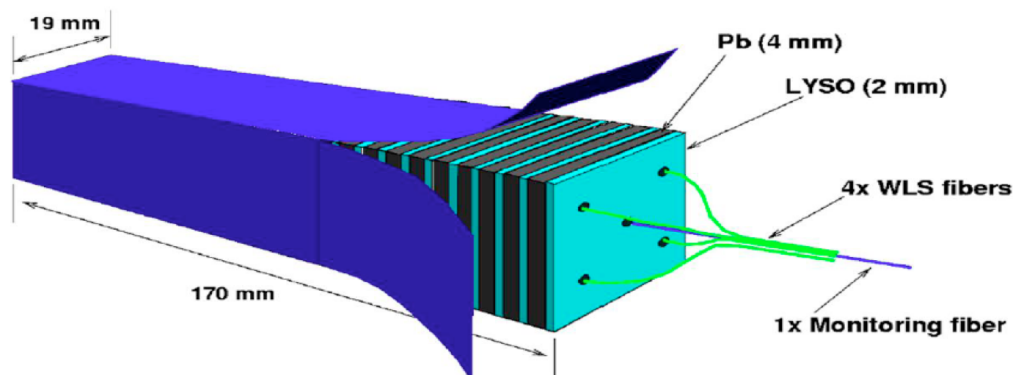

- OR High Granularity Calorimeter – “Particle Flow” to exploit CALICE-pioneered concepts
  - fine transverse & longitudinal segmentation to measure shower topology using silicon pads
- Either approach will require a solution for triggering and potential contributions in photosensors and innovative mechanics (3D printing)
  - This development is progressing fast with technology decision in ~1 year



# Let's not forget Computing

- CPU needs (per event) will grow with track multiplicity (pileup)
- Storage needs are proportional to accumulated luminosity

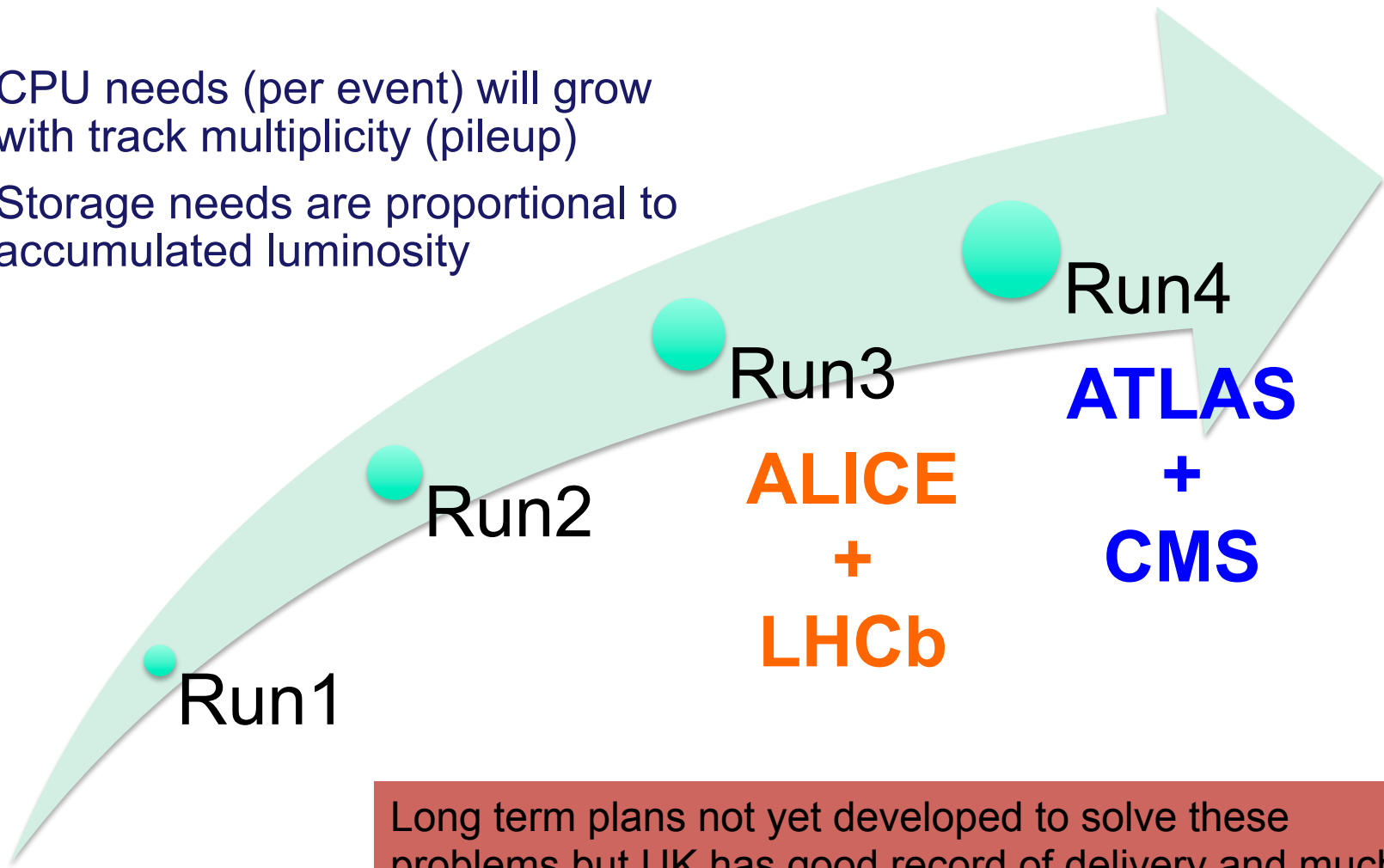

Long term plans not yet developed to solve these problems but UK has good record of delivery and much expertise to build on



# CPU: Online + Offline

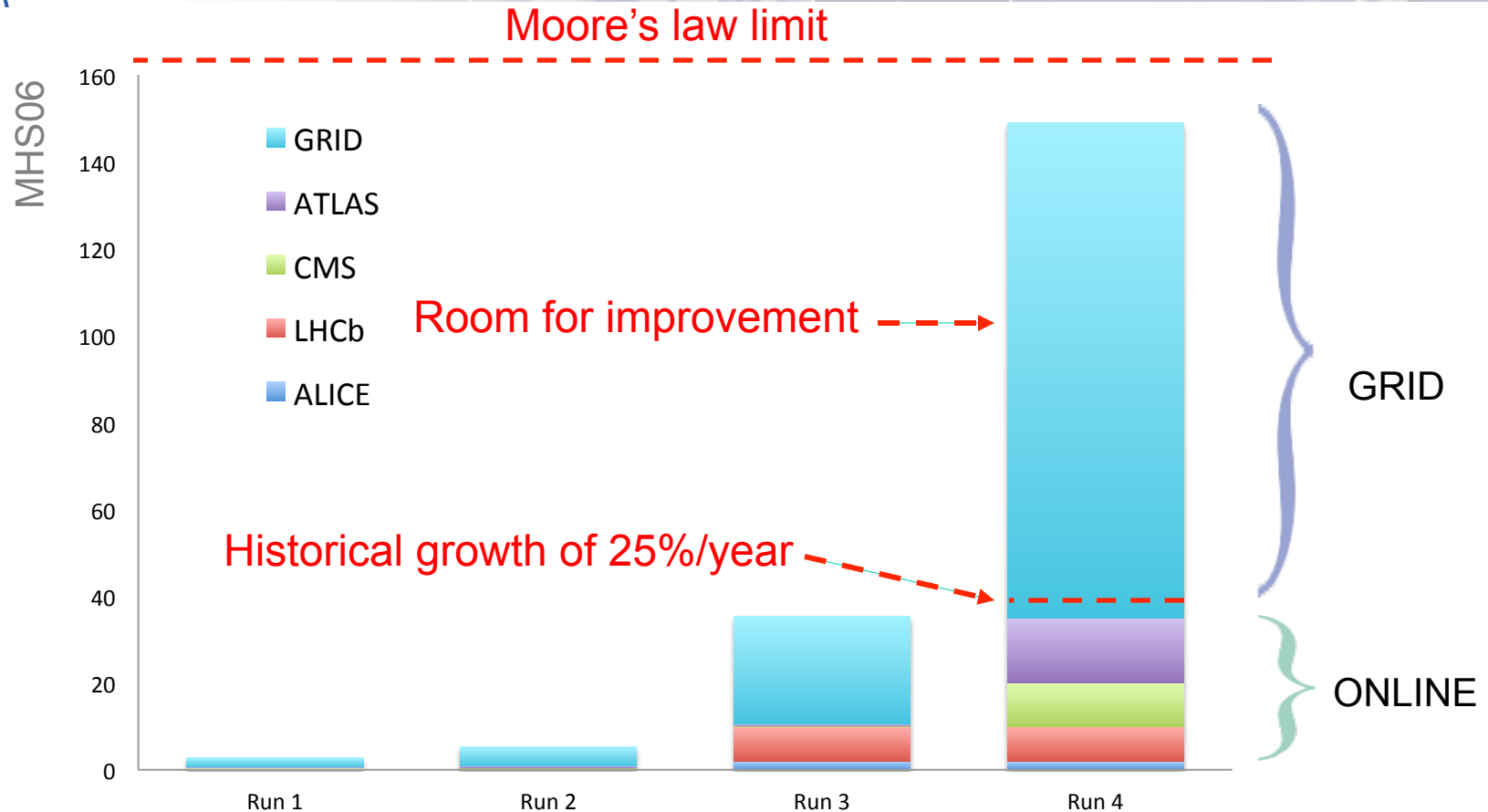

- Very rough estimate of new CPU requirements for online and offline processing per year of data taking using a simple extrapolation of current requirements scaled by the number of events.
- Little headroom left, we must work on improving the **performance**.

# UK planning and progress

- R&D on trigger and tracker, now in second project phase
  - 2009-2013
  - 2013-2019
  - outline of potential construction contributions submitted to STFC for their internal planning
- Considerable progress on which to build
  - CBC ASIC and 2S module
    - the only evidence that a track-trigger can be built
  - Phase I TMT trigger
    - the most advanced hardware, firmware and system developed
  - Concept for TMTT
    - which can be demonstrated using real hardware (unique!)
    - whose hardware can be configured in multiple ways (trigger, DAQ, ...)

# CBC development

## ➤ CBC1 (2011)

- ⊙ 128 wire-bond pads, 50 mm pitch
- ⊙ front end designed for short strips, up to 5 cm
- ⊙ DC coupled, up to 1mA leakage tolerant, both sensor polarities
- ⊙ binary unparsified readout
- ⊙ pipeline length 6.4 msec
- ⊙ chip worked well in lab and test beam (few workarounds)
- ⊙ no triggering features

## ➤ CBC2 (January, 2013)

- ⊙ 254 channels
- ⊙ ~same front end, pipeline, readout approach as CBC1
- ⊙ bump-bond layout

Only Phase II CMS ASIC in existence

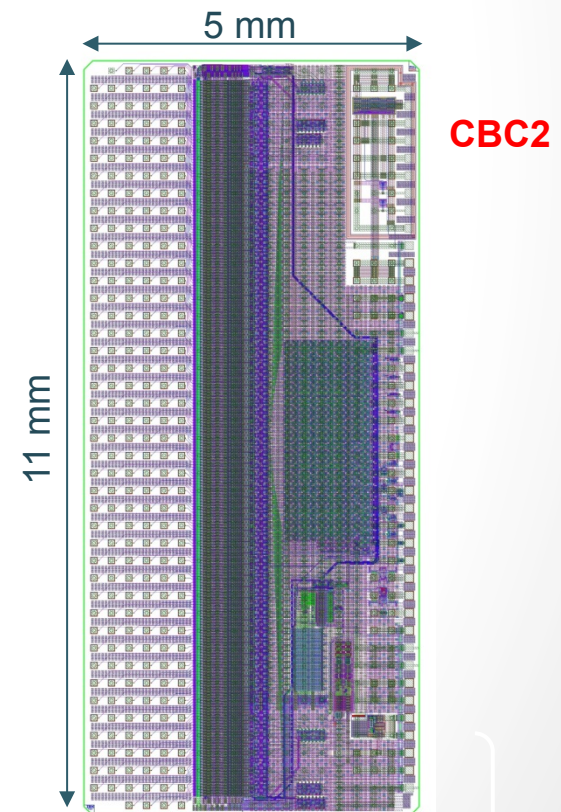
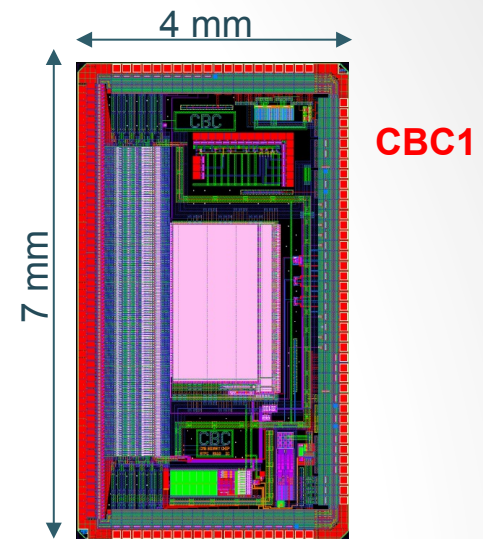

# PT modules & sensor variants

3 PT modules taken to DESY:

- 2 different sensor types
- one module left as backup

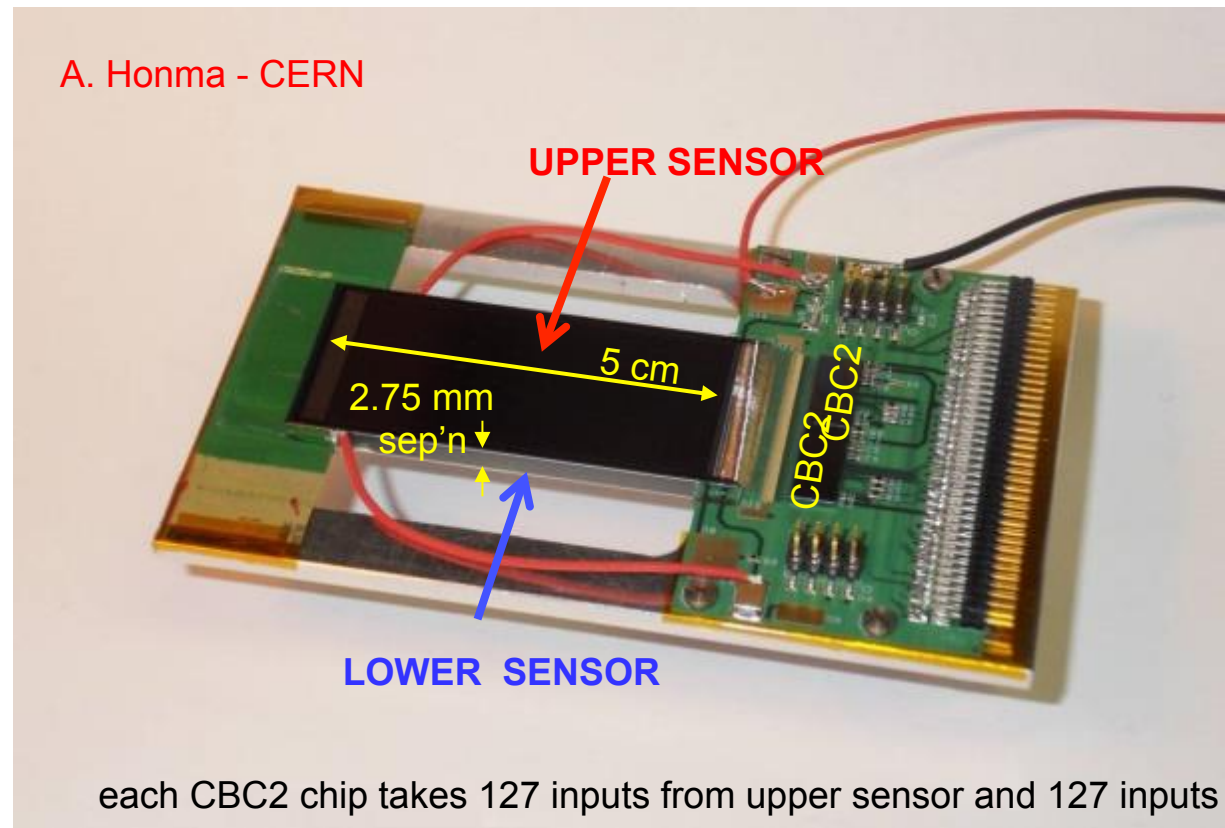

module #	sensor	sensor type	pitch [um]	thickness [um]	length [mm]	# strips	comments	tested
3	Infineon	n-type	80	300	50	256	region of disconnected channels	yes
4	CNM	p-type	90	270	54	254		yes
1	Infineon	n-type	80	300	50	256	noisy strips, disconnected channels, odd low bias behaviour	no/ backup 28

# PT module beam test at DESY

M Pesaresi, M Raymond, D Braga, F Ball, ...

- December 2013
- 4 GeV positron beam
- Datura telescope + 2 pT modules (1 fixed, 1 rotatable) with 2 different strip sensors
- Custom control and DAQ

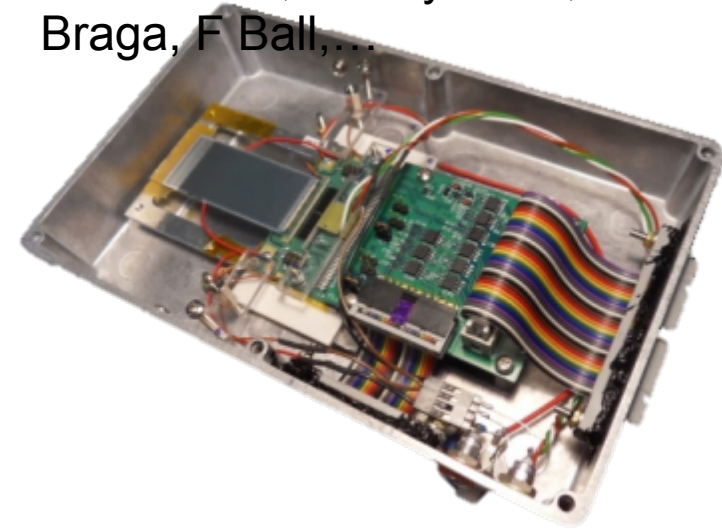

## Module #3 (FIXED)

Infineon, n-type  
 Sensor 80x300  $\mu\text{m}$   
 dL = 2.8 mm  
 Strip length = 50 mm  
 #channels = 256

## Module #4 (DUT)

CNM, p-type  
 Sensor 90x270  $\mu\text{m}$   
 dL = 2.8 mm  
 Strip length = 54 mm  
 #channels = 254

**positron beam**  
 low angular  
 divergence (small  
 angular error)

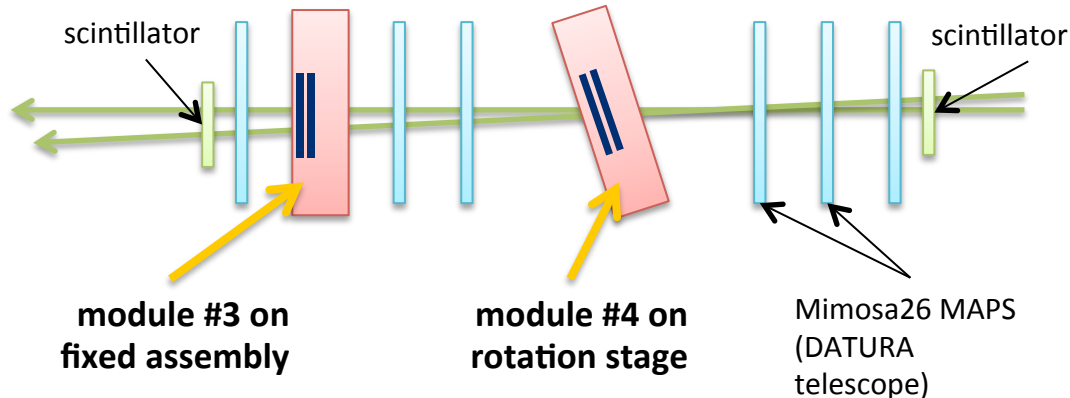

TOP VIEW: strip direction into page  
 PPAP 21 July 2014

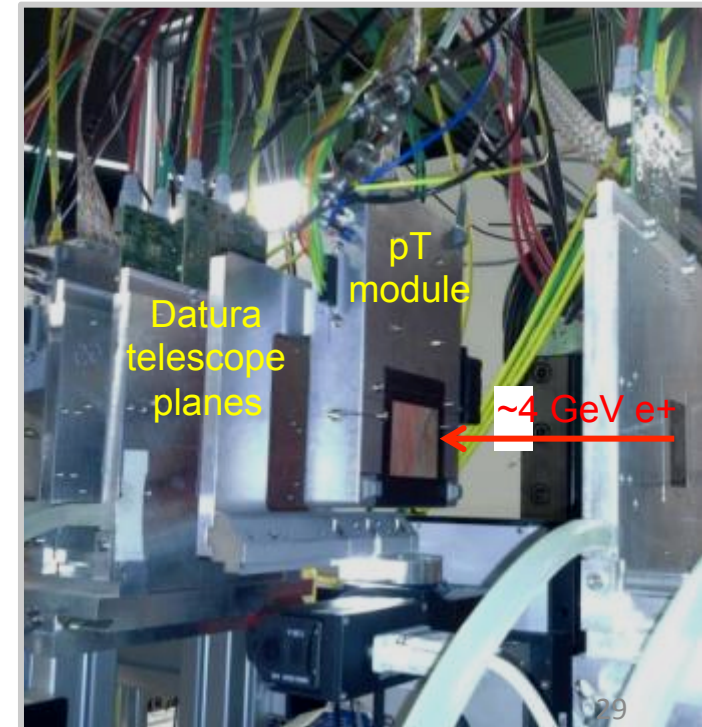

# $P_T$ cut principle demonstrated

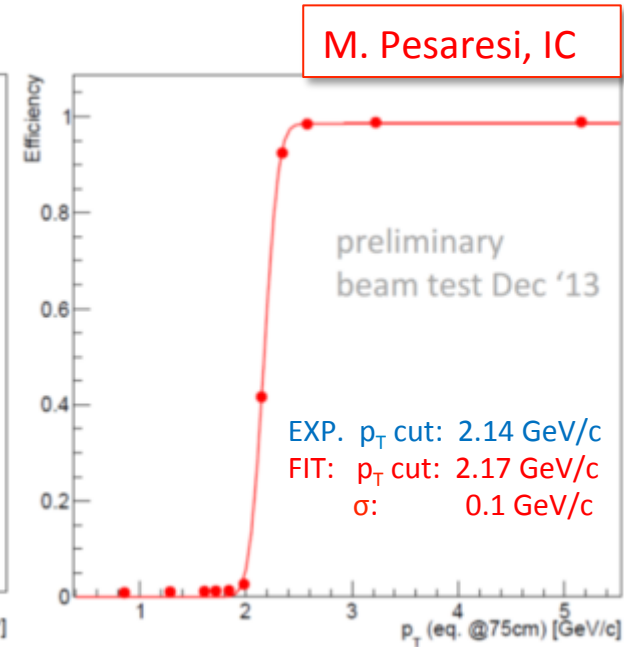
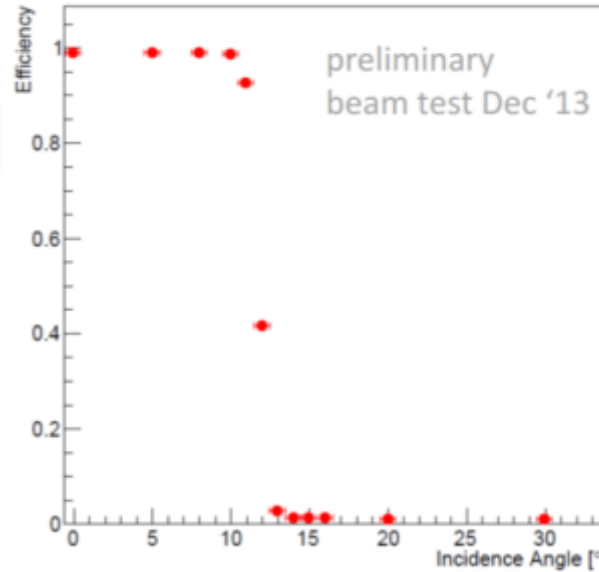
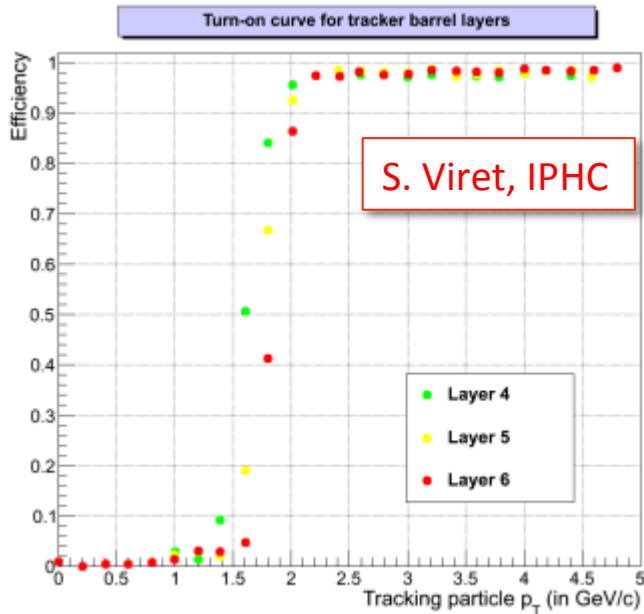

$P_T$  Selection cut: simulation



measured efficiency



reconstructed  $p_T$  cut of  $r=75\text{cm}$  layer

CBC2 correlation window was set to  $\pm 7$  strips; 0 strip offset

- $P_T$ -cut reconstructed from beam test data matches the design one exactly
- Sharp turn-on

➔ **First experimental result to prove the stub selection concept!**

# Possible layout of CMS TM Track-Trigger

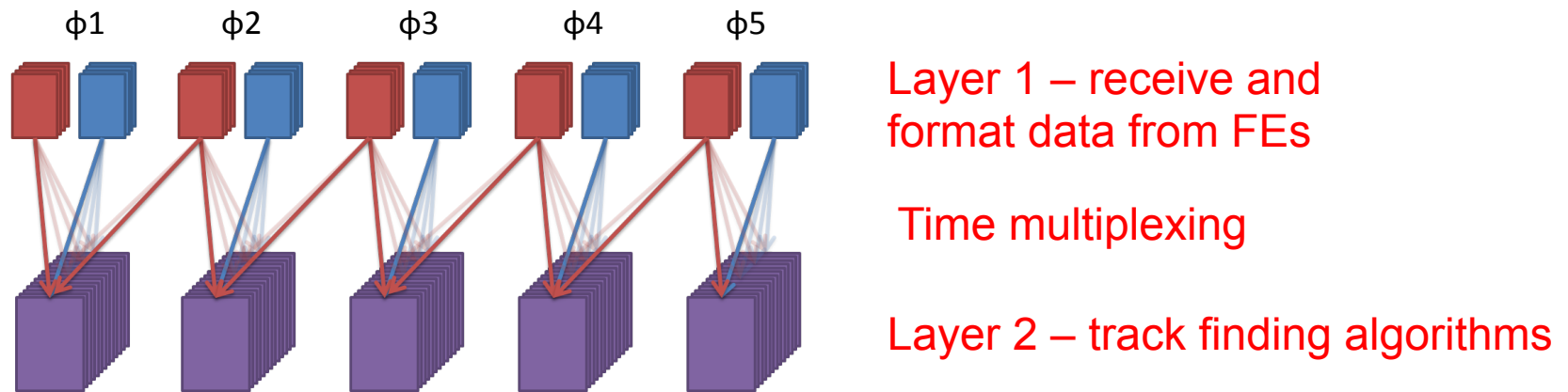

A TMTT could already be built with today's technology (MP7s)

The crucial issue is algorithms for track finding

There is a very coherent UK activity covering tracking and trigger

Developments from R&D can be exploited in several other ways

eg DAQ/trigger for Endcap calorimetry

# Summary

- There is a very strong case to continue the LHC programme
  - whether or not new discoveries are made soon
- Significant UK efforts to date in some of the most topical areas
  - Higgs, SUSY, top,  $W'$  &  $Z'$ , plus some exotic searches
    - will remain in front line for foreseeable future
- UK R&D is probably more advanced than almost any within CMS
  - we have firm foundations on which to build
- CMS plans are evolving
  - Technical Proposal in preparation for September LHCC submission
  - the upgrade scope has necessarily increased in the last two years
    - but at what seems a realistic cost
  - However effort is needed to put the whole programme on a firm financial footing
    - including leadership from CERN to develop a plan

# BACKUP MATERIAL

## Issues for the Future (*Starting now!*)

1. What is the agent of EWSB? *There is a Higgs boson!*  
Might there be several?
2. Is the Higgs boson elementary or composite? How does it interact with itself? What triggers EWSB?
3. Does the Higgs boson give mass to fermions, or only to the weak bosons? What sets the masses and mixings of the quarks and leptons? (*How*) is *fermion mass related to the electroweak scale?*
4. Are there new flavor symmetries that give insights into fermion masses and mixings?
5. What stabilizes the Higgs-boson mass below 1 TeV?

## Issues for the Future (Now!)

6. Do the different CC behaviors of LH, RH fermions reflect a fundamental asymmetry in nature's laws?
7. What will be the next symmetry we recognize? Are there additional heavy gauge bosons? Is nature supersymmetric? Is EW theory contained in a GUT?
8. Are all flavor-changing interactions governed by the standard-model Yukawa couplings? Does "minimal flavor violation" hold? If so, why?
9. Are there additional sequential quark & lepton generations? Or new exotic (vector-like) fermions?
10. What resolves the strong CP problem?

## Issues for the Future (Now!)

11. What are the dark matters? Any flavor structure?
12. Is EWSB an emergent phenomenon connected with strong dynamics? How would that alter our conception of unified theories of the strong, weak, and electromagnetic interactions?
13. Is EWSB related to gravity through extra spacetime dimensions?
14. What resolves the vacuum energy problem?
15. (When we understand the origin of EWSB), what lessons does EWSB hold for unified theories? ... for inflation? ... for dark energy?

## Issues for the Future (Now!)

16. What explains the baryon asymmetry of the universe? Are there new (CC) CP-violating phases?
17. Are there new flavor-preserving phases? What would observation, or more stringent limits, on electric-dipole moments imply for BSM theories?
18. (How) are quark-flavor dynamics and lepton-flavor dynamics related (beyond the gauge interactions)?
19. At what scale are the neutrino masses set? Do they speak to the TeV scale, unification scale, Planck scale, ...?
20. How are we prisoners of conventional thinking?